

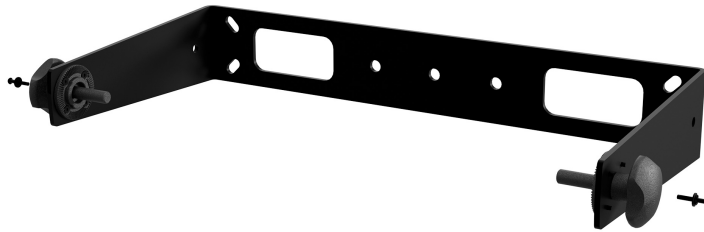

H-BR TT 515

HORIZONTAL MOUNT BRACKET



Description H-BR Horizontal Mount Bracket for TT 515-A speaker. It features robust brackets and hardware to mount the speaker to a wall, ceiling, or truss in horizontal configuration. Adjustable inclination allows obtaining the desired sound coverage.

- Features**
- › Strong steel construction
 - › Adjustable inclination
 - › Painted with black, scratch-resistant paint
 - › Safe and quick loudspeaker installation

Part Number	13360459 H-BR TT 515	Black	EAN 8024530018948
	13360640 H-BR 009 W	White	EAN 8024530022327



H-BR TT 515

HORIZONTAL MOUNT BRACKET

Line Art 2D

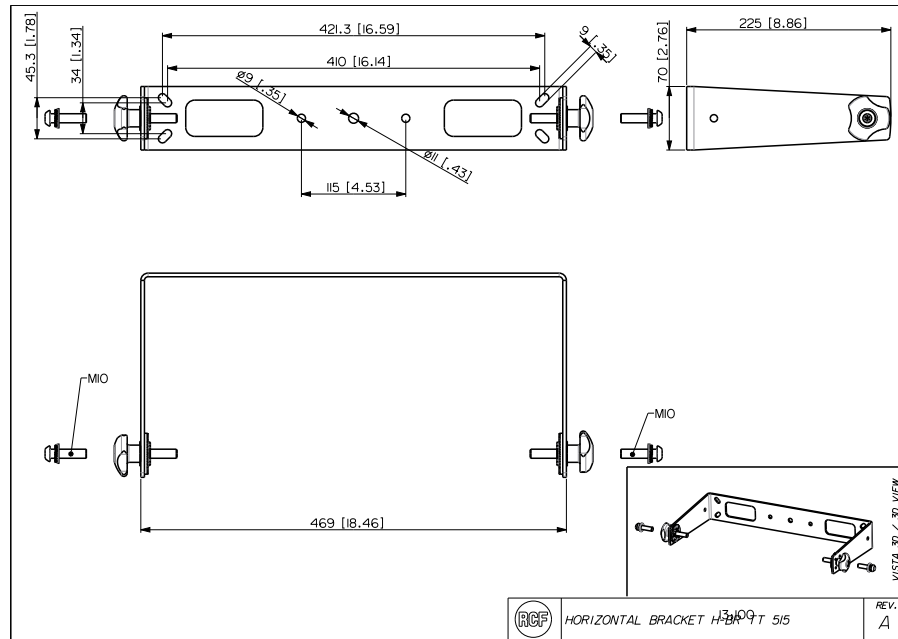

TECHNICAL SPECIFICATIONS

General specifications
Standard compliance
Physical specifications
Size

Protections
Safety agency
Color
Weight

Scratches
CE compliant
Black, White
1.6 kg / 3.53 lbs