



# V-BR ART 915

## VERTICAL MOUNT BRACKET



### Description

V-BR Vertical Mount Bracket for ART 9 Series 15" models. It features robust brackets and hardware to mount the speaker system to a wall, ceiling, or truss in vertical configuration. Adjustable inclination allows obtaining the desired sound coverage.

### Standard compliance

Safety agency

CE compliant

### Size

Weight

5.6 kg / 12.35 lbs

### Physical specifications

Color

Black

### Line Art 2D

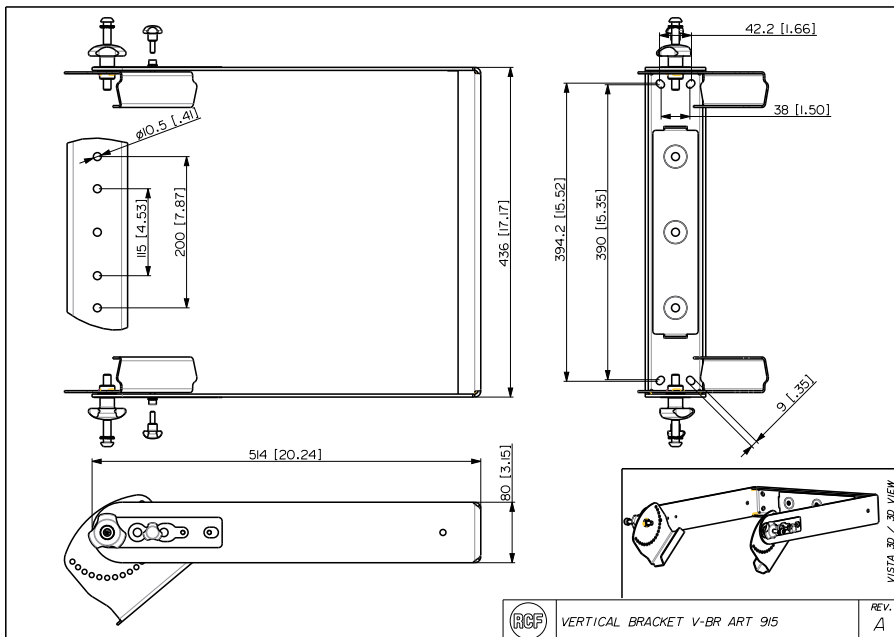

### Part Number

13360480 V-BR ART 915

Black

EAN 8024530019181

### Technical Specifications

Products are continually improved. All specifications are therefore subject to change without notice.