



KRT-WH 6X HDL 6

KART WITH WHEELS



Description

Cart to store and transport up to 6 modules for HDL 6-A or HDL 26-A or HL 6.

Standard compliance

Safety agency

CE compliant

Size

Weight

10 kg / 22.05 lbs

Physical specifications

Color

Black

Line Art 2D

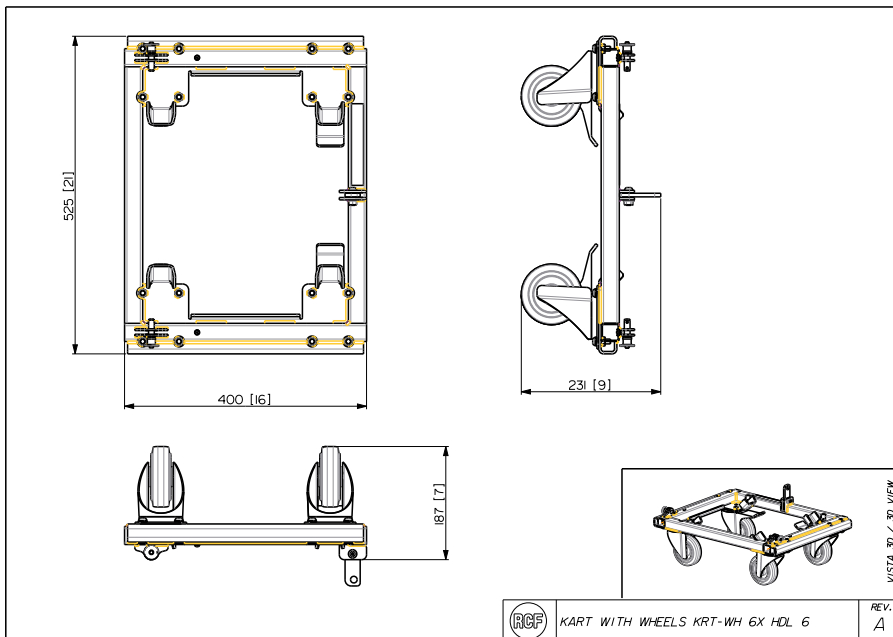

Part Number

13360366 KRT-WH 6X HDL 6

Black

EAN 8024530014421

Technical Specifications

Products are continually improved. All specifications are therefore subject to change without notice.