



# V-BR TT 08 II

VERTIKALER MONTAGEBÜGEL



## Beschreibung

Standardkonformität  
Größe  
Physikalische daten

Safety agency  
Gewicht  
Farbe

CE compliant  
1.7 kg / 3.75 lbs  
Black

## Line Art 2D

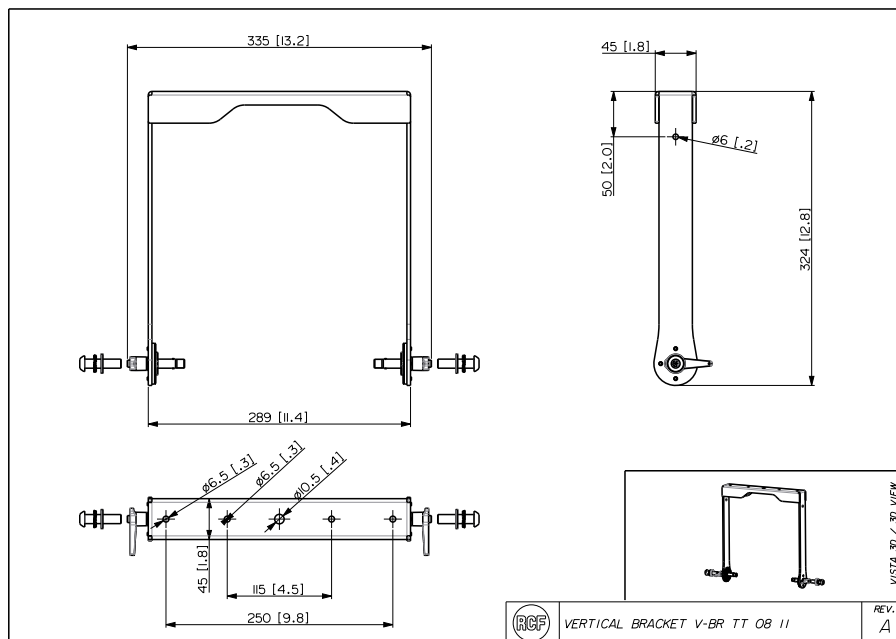

Artikel-nummer

13360400 V-BR TT 08 II

Black

EAN 8024530016296

Spezifikationen

Products are continually improved. All specifications are therefore subject to change without notice.