



KRT-WH 3X HDL 38

KRT-WH 3X HDL 38



Beschreibung WARENKORB MIT RÄDERN FÜR 3 HDL 38

Standardkonformität Safety agency

CE compliant

Größe Gewicht

20 kg / 44.09 lbs

Line Art 2D

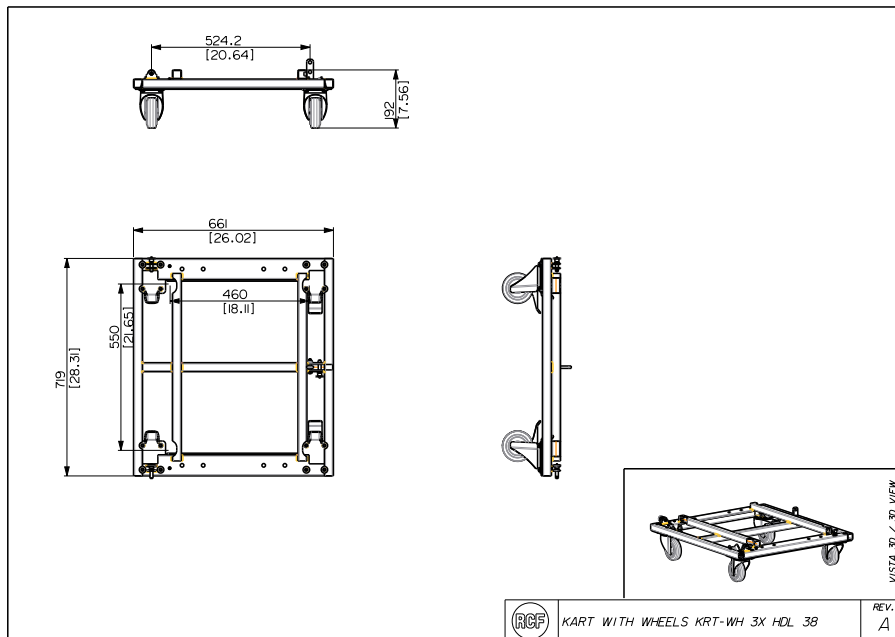

Artikel-nummer 13360430 KRT-WH 3X HDL 38

EAN 8024530016777

Spezifikationen

Products are continually improved. All specifications are therefore subject to change without notice.