

RCF VERTICAL BRACKET FOR KX 45

For **temporary installations**, slightly unscrew both knobs and tilt the speaker, then secure both knobs screwing them tightly.

WARNING: do not unscrew the knobs completely.

*Per **installazioni temporanee**, svitare leggermente le due manopole e inclinare il diffusore, quindi ri-avvitarle saldamente.*

ATTENZIONE: non svitare completamente le manopole.

For **permanent installations**, remove both knobs and replace them with the M10 screws and washers supplied with the accessory.

*Per **installazioni fisse**, rimuovere le manopole e sostituirle con le viti M10 e relative rondelle fornite in dotazione.*

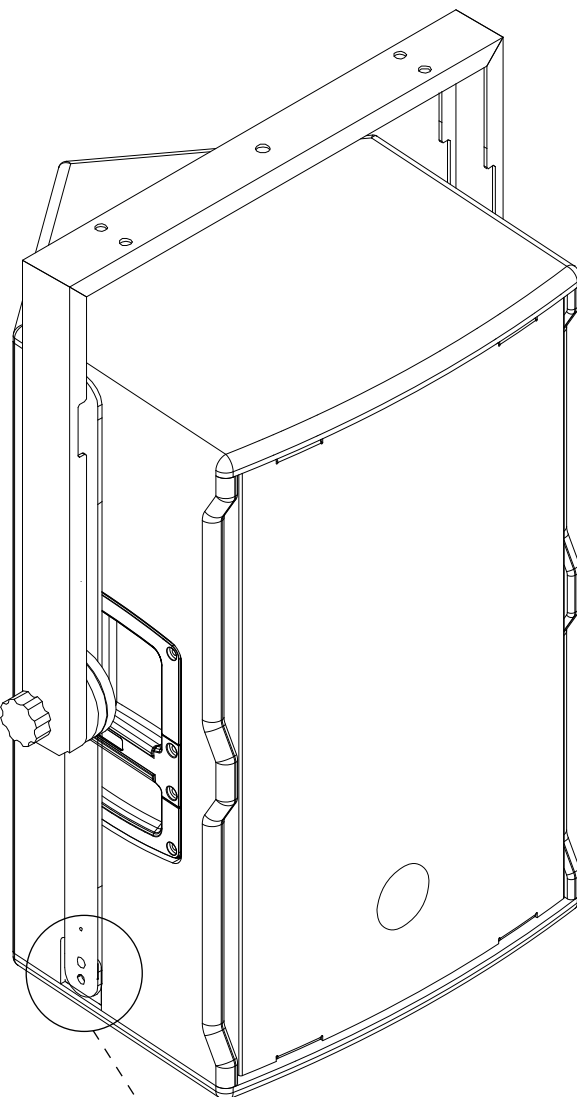
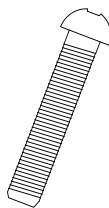

For **temporary installations**, secure the speaker to the bracket inserting the 4 supplied pins into these holes.

*Per **installazioni temporanee**, fissare il diffusore alla staffa inserendo in questi fori i 4 pin forniti in dotazione.*

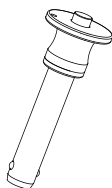

For **permanent installations**, secure the speaker to the bracket screwing the 4 M8 supplied screws and washers into these holes.

*Per **installazioni fisse**, fissare il diffusore alla staffa utilizzando le 4 viti M8 e relative rondelle fornite in dotazione utilizzando questi fori.*

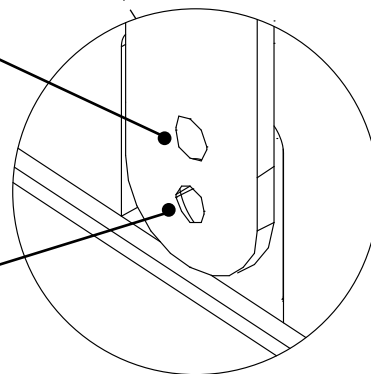
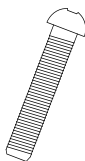

ON **PERMANENT INSTALLATIONS**, THE USE OF A MEDIUM STRENGTH THREADLOCKER (LOCTITE 243 OR SIMILAR) IS RECOMMENDED ON THE SCREW THREADS.

*NELLE **INSTALLAZIONI Fisse**, SI CONSIGLIA L'UTILIZZO DI FRENAFILETTI MEDIO (LOCTITE 243 O EQUIVALENTE) SUI FILETTI DELLE VITI.*