

OWNER MANUAL

HDL 28-A

ACTIVE TWO-WAY
LINE ARRAY MODULE

HDL 36-AS

ACTIVE SUBWOOFER
ARRAY MODULE



1. INTRODUCTION

The demands of modern sound reinforcement systems are higher than ever before. Besides pure performance - high sound pressure levels, constant directivity and sound quality other aspects are important for rental and production companies such as reduced weight and ease of use to optimize transport and rigging time.

HDL 28-A is changing the concept of compact arrays, providing primary performances to an extended market of professional users.

2. GENERAL SAFETY INSTRUCTION AND WARNINGS

IMPORTANT NOTE

Before connecting using or rigging the system, please read this instruction manual carefully and keep it on hand for future reference. The manual is to be considered an integral part of the product and must accompany the system when it changes ownership as a reference for correct installation and use as well as for the safety precautions. RCF S.p.A. will not assume any responsibility for the incorrect installation and/or use of the product.

WARNING

- To prevent the risk of fire or electric shock, never expose this equipment to rain or humidity.
- The system HDL line arrays should be rigged and flown by professional riggers or trained personnel under professional riggers' supervision.
- Before rigging the system carefully read this manual.

SAFETY PRECAUTIONS

1. All the precautions, in particular the safety ones, must be read with special attention, as they provide important information.

Power supply from mains. The mains voltage is sufficiently high to involve a risk of electrocution; install and connect this product before plugging it in. Before powering up, make sure that all the connections have been made correctly and the voltage of your mains corresponds to the voltage shown on the rating plate on the unit, if not, please contact your RCF dealer. The metallic parts of the unit are earthed through the power cable. An apparatus with CLASS I construction shall be connected to a mains socket outlet with a protective earthing connection. Protect the power cable from damage; make sure it is positioned in a way that it cannot be stepped on or crushed by objects. To prevent the risk of electric shock, never open this product: there are no parts inside that the user needs to access.

Be careful: jointly to POWERCON connectors type NAC3FCA (power-in) and NAC3FCB (power-out) supplied by manufacturer, the following power cords compliant to national standard shall be used:

EU: cord type H05VV-F 3G 3x2.5 mm² - Standard IEC 60227-1

JP: cord type VCTF 3x2 mm²; 15Amp/120V~ - Standard JIS C3306

US: cord type SJT/SJTO 3x14 AWG; 15Amp/125V~ - Standard ANSI/UL 62

2. Make sure that no objects or liquids can get into this product, as this may cause a short circuit. This apparatus shall not be exposed to dripping or splashing. No objects filled with liquid, such as vases, shall be placed on this apparatus. No naked sources (such as lighted candles) should be placed on this apparatus.
3. Never attempt to carry out any operations, modifications or repairs that are not expressly described in this manual. Contact your authorized service centre or qualified personnel should any of the following occur:
 - **the product does not function (or functions in an anomalous way).**
 - **the power cable has been damaged.**
 - **objects or liquids have got in the unit.**
 - **the product has been subject to a heavy impact.**
4. If this product is not used for a long period, disconnect the power cable.
5. If this product begins emitting any strange odours or smoke, switch it off immediately and disconnect the power cable.
6. Do not connect this product to any equipment or accessories not foreseen. For suspended installation, only use the dedicated anchoring points and do not try to hang this product by using elements that are unsuitable or not specific for this purpose. Also check the suitability of the support surface to which the product is anchored (wall, ceiling, structure, etc.), and the components used for attachment (screw

anchors, screws, brackets not supplied by RCF etc.), which must guarantee the security of the system / installation over time, also considering, for example, the mechanical vibrations normally generated by transducers. To prevent the risk of falling equipment, do not stack multiple units of this product unless this possibility is specified in the user manual.

7. RCF S.p.A. strongly recommends this product is only installed by professional qualified installers (or specialised firms) who can ensure correct installation and certify it according to the regulations in force.
The entire audio system must comply with the current standards and regulations regarding electrical systems.
8. Supports and trolleys.
The equipment should be only used on trolleys or supports, where necessary, that are recommended by the manufacturer. The equipment / support / trolley assembly must be moved with extreme caution. Sudden stops, excessive pushing force and uneven floors may cause the assembly to overturn.
9. There are numerous mechanical and electrical factors to be considered when installing a professional audio system (in addition to those which are strictly acoustic, such as sound pressure, angles of coverage, frequency response, etc.).
10. Hearing loss.
Exposure to high sound levels can cause permanent hearing loss. The acoustic pressure level that leads to hearing loss is different from person to person and depends on the duration of exposure. To prevent potentially dangerous exposure to high levels of acoustic pressure, anyone who is exposed to these levels should use adequate protection devices. When a transducer capable of producing high sound levels is being used, it is therefore necessary to wear ear plugs or protective earphones. See the manual technical specifications to know the maximum sound pressure level.

To prevent the occurrence of noise on line signal cables, use screened cables only and avoid putting them close to:

- **Equipment that produces high-intensity electromagnetic fields.**
- **Power cables**
- **Loudspeaker lines.**

OPERATING PRECAUTIONS

- **Place this product far from any heat sources and always ensure an adequate air circulation around it.**
- **Do not overload this product for a long time.**
- **Never force the control elements (keys, knobs, etc.).**
- **Do not use solvents, alcohol, benzene or other volatile substances for cleaning the external parts of this product.**

GENERAL OPERATING PRECAUTIONS

- Do not obstruct the ventilation grilles of the unit. Situate this product far from any heat sources and always ensure adequate air circulation around the ventilation grilles.
- Do not overload this product for extended periods of time.
- Never force the control elements (keys, knobs, etc.).
- Do not use solvents, alcohol, benzene or other volatile substances for cleaning the external parts of this product.

CAUTION

To prevent electric shock hazard, do not connect to mains power supply while grille is removed

FCC NOTES

This equipment has been tested and found to comply with the limits for a Class A digital device, pursuant to Part 15 of the FCC Rules. These limits are designed to provide reasonable protection against harmful interference when the equipment is operated in a commercial environment. This equipment generates, uses, and can radiate radio frequency energy, and if it is not installed and used in accordance with the instruction manual, it may cause harmful interference to radio communications. Operation of this equipment in a residential area is likely to cause harmful interference, in which case the user will be required to correct the interference at his own expense.

Modifications: Any modifications made to this device that are not approved by RCF may void the authority granted to the user by the FCC to operate this equipment.

3. THE SYSTEMS

THE HDL 28-A SYSTEM

The HDL 28-A is a true active high power ready to use touring system from small to medium size events, indoors and outdoors. Equipped with 2x8" woofers and one 3" drivers, it offers excellent playback quality and high sound pressure levels with a built in 2200 W powerful digital amplifier that delivers superior SPL, while reducing energy requirement.

Each component, from the power supply to the input board with DSP, to the output stages to woofers and drivers, has been consistently and specially developed by RCF's experienced engineering teams for the realization of the HDL 28-A system, with all components carefully matched to each other.

This complete integration of all components allows not only superior performance and maximum operational reliability, but also provides users easy handling and plug & play comfort.

Besides this important fact, active speakers offer valuable advantages: while passive speakers often need long cable runs, the energy loss due to the cable resistance is a huge factor. This effect is not seen in powered speakers where the amplifier is just a couple of centimeters away from the transducer.

Using advanced neodymium magnets and a groundbreaking new housing constructed from lightweight composite polypropylene, it has a remarkably low weight for easy handling and flying.

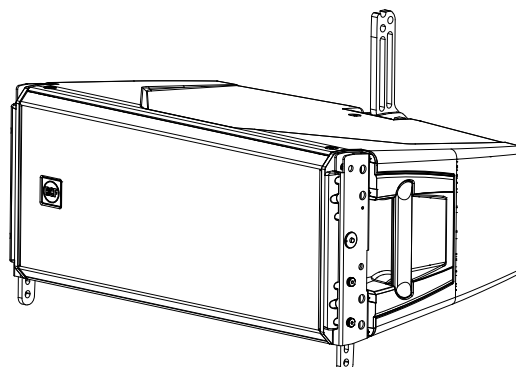

THE HDL 36-AS SYSTEM

The HDL 36-AS is the ideal flyable bass complement for the HDL 28-A array system. It features one 4.0" voice coil, 15" Neodymium woofer to handle 135 dB SPL Max from 40 Hz to 140 Hz with maximum linearity and low distortion. The built-in 3200 Watt Class-D amplifier delivers excellent playback clarity and up to 135 decibels SPL max. With RDNet compatibility, the HDL 36-AS is part of the professional HDL System.

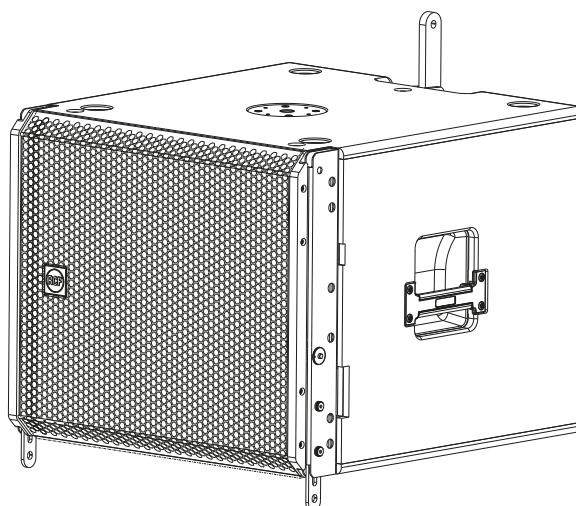

4. POWER REQUIREMENTS AND SET-UP

⚠ WARNING

- The system is designed to operate in hostile and demanding situations. Nevertheless it is important to take extremely care of the AC power supply and set up a proper power distribution.
- The system is designed to be GROUNDED. Always use a grounded connection.
- PowerCon appliance coupler is a AC mains power disconnection device and must be readily accessible during and after the installation.

VOLTAGE

The HDL 28-A amplifier is designed to work within the following AC Voltage limits: minimum voltage 100 Volt, maximum voltage 260 Volt. If the voltage goes below the minimum admitted voltage the system stops working. If the voltage goes higher than the maximum admitted voltage the system can be seriously damaged. To obtain the best performances from the system it is very important that the voltage drop it is as low as possible.

CURRENT

The following are the long term and peak current requirement for each HDL 28-A module:

VOLTAGE	LONG TERM
230 Volt	3.2 A
115 Volt	6.3 A

The total current requirement is obtained multiplying the single current requirement by the number of modules. To obtain the best performances make sure that the total burst current requirement of the system doesn't create a significant voltage drop on the cables.

GROUNDING

Make sure that all the system is properly grounded. All the grounding points shall be connected to the same ground node. This will improve reducing hums in the audio system.

HDL 28-A, AC CABLES DAISY CHAINS

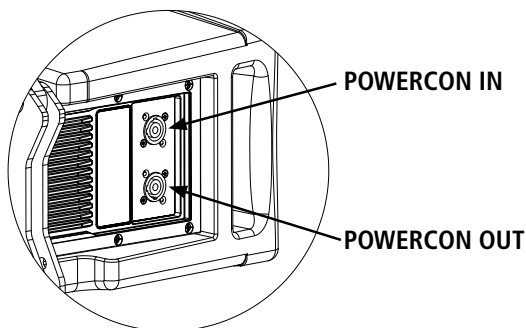

Each HDL 28-A module is provided with a Powercon outlet to daisy chain other modules. The maximum number of modules that is possible to daisy chain is:

230 VOLT: 6 modules total
115 VOLT: 3 modules total

⚠ WARNING - RISK OF FIRE

A superior number of modules in daisy chain will exceed the Powercon connector maximum ratings and create a potentially dangerous situation.

POWERING FROM THREE PHASE

When the system is powered from a three phase power distribution it is very important to keep a good balance in the load of each phase of the AC power. It is very important to include subwoofers and satellites in power distribution calculation: both subwoofers and satellites shall be distributed between the three phases.

5. RIGGING THE SYSTEM

RCF has developed a complete procedure to set up and hang an HDL 28-A line array system starting from software data, enclosures, rigging, accessories, cables, until the final installation.

GENERAL RIGGING WARNINGS AND SAFETY PRECAUTIONS

- Suspending loads should be done with extreme caution.
- When deploying a system always wear protective helmets and footwear.
- Never allow people to pass under the system during the installation process.
- Never leave the system unattended during the installation process.
- Never install the system over areas of public access.
- Never attach other loads to the array system.
- Never climb the system during or after the installation
- Never expose the system to extra loads created from the wind or snow.

WARNING

- The system must be rigged in accordance with the laws and regulations of the Country where the system is used. It is responsibility of the owner or rigger to make sure that the system is properly rigged in accordance with Country and local laws and regulations.
- Always check that all the parts of the rigging system that are not provided from RCF are:
 - appropriate for the application
 - approved, certified and marked
 - properly rated
 - in perfect condition
- Each cabinet support the full load of the part of the system below. It is very important that each single cabinet of the system is properly checked

“RCF SHAPE DESIGNER” SOFTWARE AND SAFETY FACTOR

The suspension system is designed to have a proper safety factor (configuration dependent). Using the “RCF Easy Shape Designer” software it is very easy to understand safety factors and limits for each specific configuration. To better comprehend in which safety range the mechanics are working a simple introduction is needed: HDL 28-A arrays’ mechanics are built with certified UNI EN 10025 Steel. RCF prediction software calculates forces on every single stressed part of the assembly and shows the minimum safety factor for every link. Structural steel has a stress-strain (or equivalent Force-Deformation) curve as in the following:

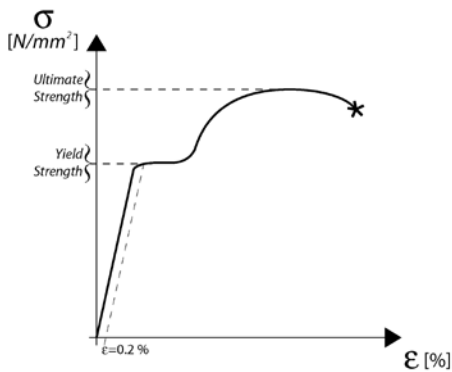

The curve is characterized by two critical points: the **Break Point** and the **Yield Point**. The tensile ultimate stress is simply the maximum stress attained. Ultimate tensile stress is commonly used as a criterion of the strength of the material for structural design, but it should be recognized that other strength properties may often be more important. One of these is certainly the Yield Strength. Stress-strain diagram of structural steel exhibit a sharp break at a stress below the ultimate strength. At this critical stress, the material elongates considerably with no apparent change in stress. The stress at which this occurs is referred to as the Yield Point. Permanent deformation may be detrimental, and the industry adopted 0.2% plastic strain as an arbitrary limit that is considered acceptable by all regulatory agencies. For tension and compression, the corresponding stress at this offset strain is defined as the yield.

In our prediction software the **Safety Factors** are calculated considering the **Maximum Stress Limit** equal to the **Yield Strength**, according with many international standards and rules.

The resulting Safety Factor is the minimum of all the calculated safety factors, for each link or pin.

This is where you are working with a **SF=7**

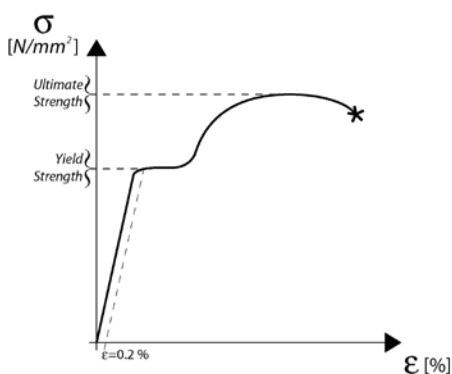

Depending on local safety regulations and on the situation, the required safety factor can vary. It is responsibility of the owner or rigger to make sure that the system is properly rigged in accordance with Country and local laws and regulations.

The “RCF Shape Designer” software gives detailed information of the safety factor for each specific configuration. The results are classified in four classes:

GREEN		SAFETY FACTOR	> 7	SUGGESTED
YELLOW	4 >	SAFETY FACTOR	> 7	
ORANGE	1.5 >	SAFETY FACTOR	> 4	
RED		SAFETY FACTOR	> 1.5	NEVER ADMITTED

⚠ WARNING

- The safety factor is the result of the forces acting on fly bar's and system's front and rear links and pins and depends on many variables:
 - number of cabinets
 - fly bar angles
 - angles from cabinets to cabinets. If one of the cited variables change the safety factor **MUST BE** recalculated using the software before rigging the system.
- In case the fly bar is picked up from 2 motors make sure that the fly bar angle is correct. An angle different from the angle used in the prediction software can be potentially dangerous. Never allow persons to stay or pass under the system during the installation process.
- When the fly bar is particularly tilted or the array is very curved the centre of gravity can move out from the rear links. In this case the front links are in compression and the rear links are supporting the total weight of the system plus the front compression. Always check very carefully with the "RCF Easy Shape Designer" software all this kind of situations (even with a small number of cabinets).

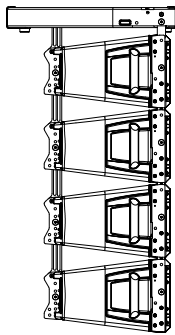

System particularly tilted

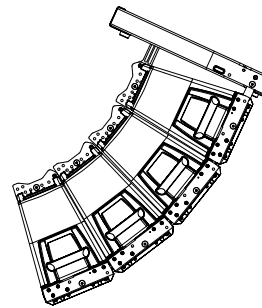

System very curved

PREDICTION SOFTWARE – SHAPE DESIGNER

RCF Easy Shape Designer is a temporary software, useful for the setup of the array, for mechanics and for proper preset suggestions.

The optimal setting of a loudspeaker array cannot ignore the basics of acoustics and the awareness that many factors contribute to a sonic result that matches expectations. RCF provides the user with simple instruments that help the setting of the system in an easy and reliable way.

This software will soon be replaced by a more complete software for multiple arrays and complex venue simulation with maps and graphs of the results.

RCF recommends this software to be used for each type of HDL 28-A configuration.

SOFTWARE INSTALLATION

The software was developed with Matlab 2015b and requires Matlab programming libraries. At the very first installation user should refer to the installation package, available from the RCF website, containing the Matlab Runtime (ver. 9) or the installation package that will download the Runtime from the web. Once the libraries are correctly installed, for all the following version of the software the user can directly download the application without the Runtime. Two versions, 32-bit and 64-bit, are available for the download.

IMPORTANT: Matlab no longer supports Windows XP and hence RCF EASY Shape Designer (32 bit) doesn't work with this OS version.

You may wait a few seconds after the double click on the installer because the software checks if Matlab Libraries are available. After this step the installation begins. Double-click the last installer (check for the last release in the download section of our website) and follow the next steps.

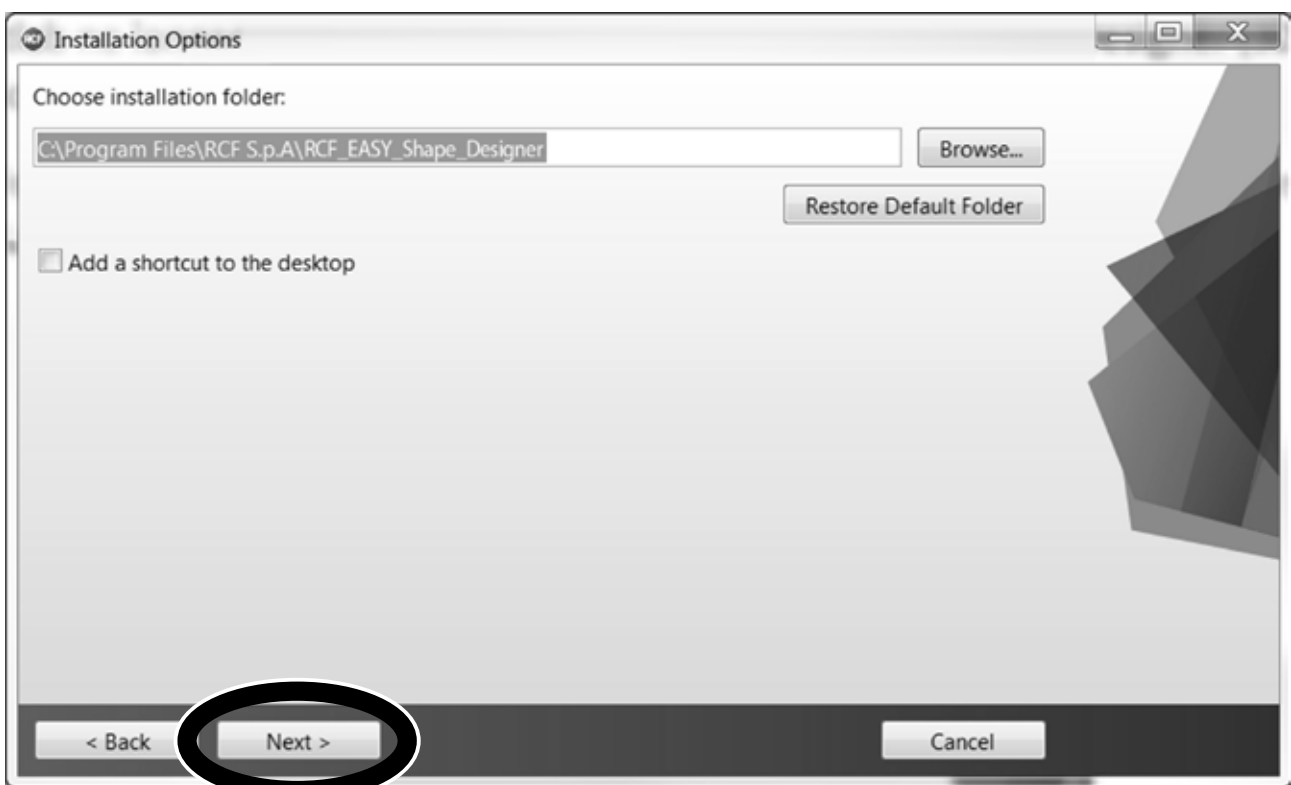

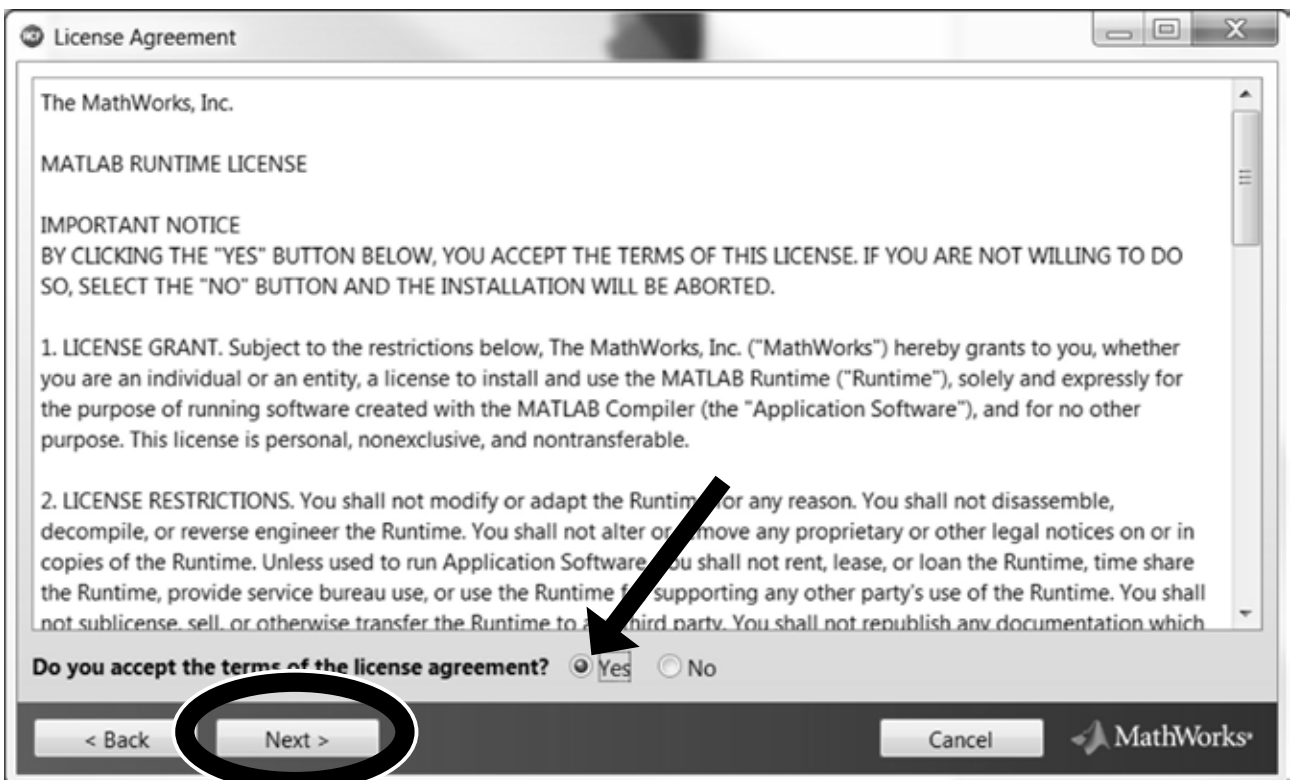

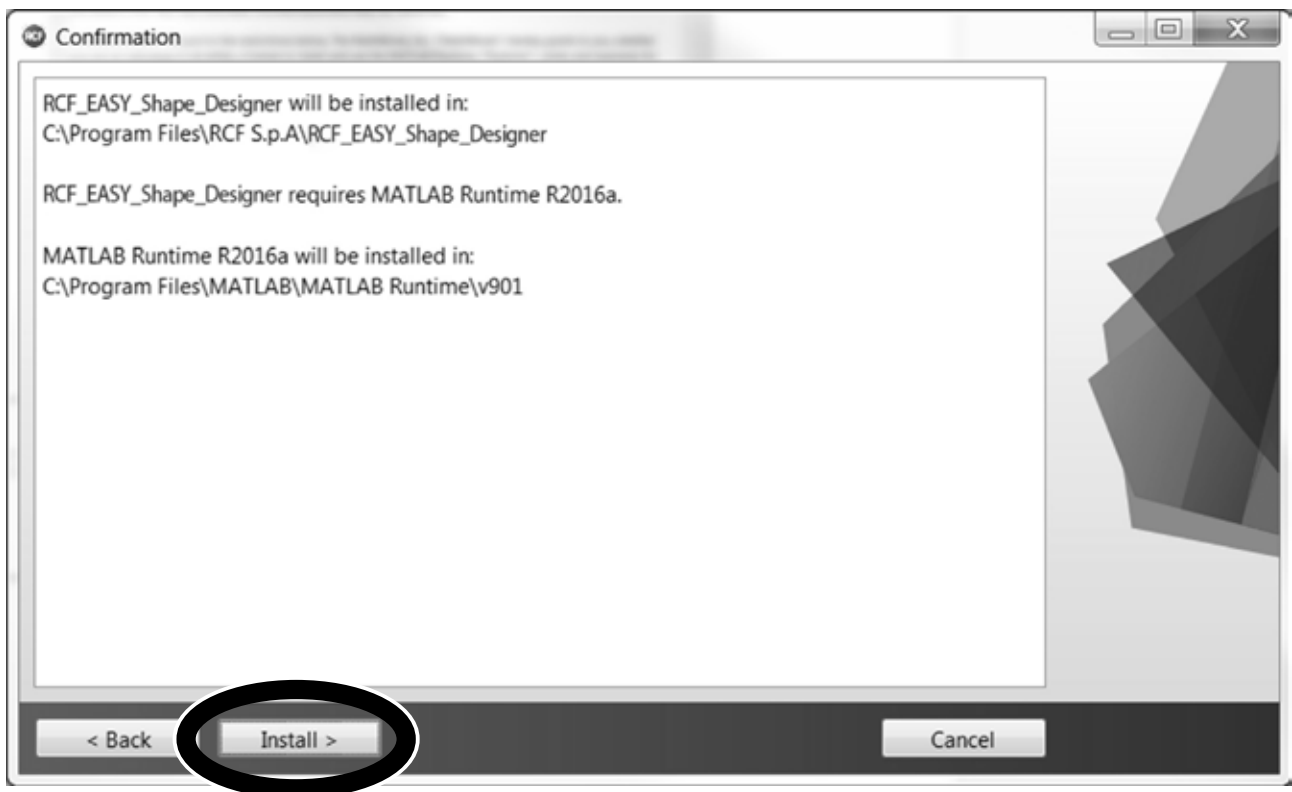

After the choice of folders for HDL28 Shape Designer software (Figure 2) and Matlab Libraries Runtime the installer takes a couple of minutes for the installation procedure.

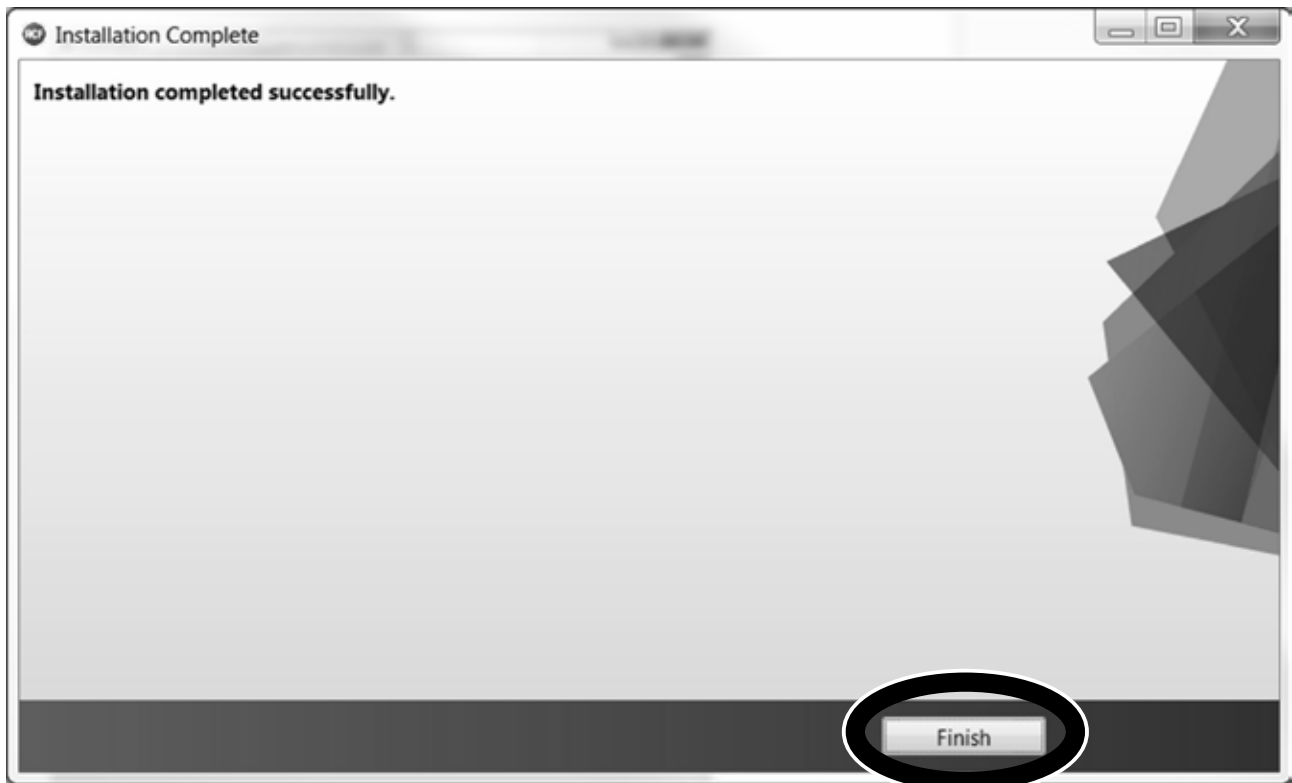

DESIGNING THE SYSTEM

The RCF Easy Shape Designer software is divided into two macro sections: the left part of the interface is dedicated to project variables and data (size of audiences to cover, height, number of modules, etc.), the right part shows the processing results.

At first the user should introduce the audience data choosing the proper pop-up menu depending on the size of the audience and introducing the geometrical data. It is also possible to define the height of the listener.

The second step is the array definition selecting the number of cabinets in the array, the hanging height, the number of hanging points and the kind of available flybars. When selecting two hanging points consider those points positioned at the flybar extremes.

The height of the array should be considered referred to the bottom side of the flybar, as shown in the picture below.

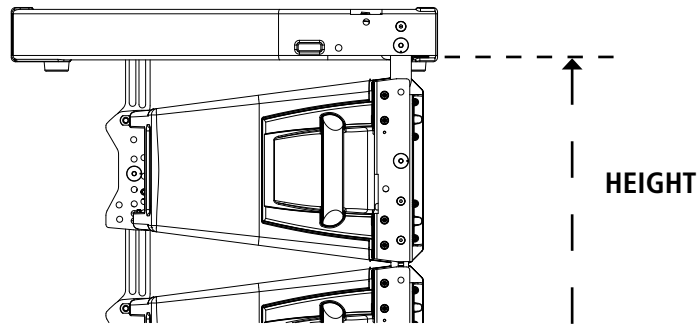

After entering all the data input in the left part of the user interface, by pressing the AUTOSPLAY button the software will perform:

- Hanging point for the shackle with A or B position indicated if a single pickup point is selected, rear and front load if two pickup points are selected.
- Flybar tilt angle and cabinet splays (angles that we have to set to each cabinet before lifting operations).
- Inclination that each cabinet will take (in case of one pick up point) or will have to take if we were to tilt the cluster with the use of two engines. (two pick up points).
- Total load and Safety Factor calculation: if the selected setup doesn't give Safety Factor > 1.5 the text message shows in red color the failure to meet the minimum conditions of mechanical safety.
- Low Frequency Presets (a single preset for all the array) for RDNet use or for rear panel rotary knob use ("Local").
- High Frequency Presets (a preset for every array module) for RDNet use or for rear panel rotary knob use ("Local").

VENUE

	x	y
min Audience 1 [m]	6	0
max Audience 1 [m]	25	0
Listener Height [cm]	170	
min Audience 2 [m]	27	2.5
max Audience 2 [m]	55	7
Listener Height [cm]	170	
N. of Audience	2	

ARRAY

N. of cabinets: 12
 Height [m] *: 9
 N. of pickup points: 1
 Flybar type: Short

ENVIRONMENT

Temp. [°C]: 20
 Humidity [%]: 60

* from the ground to the bottom side of the flybar

RESULTS

Total Load [Kg]: 722
 Hanging Points: 14-15A
 Front Pick Load [Kg]: --
 Rear Pick Load [Kg]: --
 SAFETY FACTOR: 8.9 OK

FLYBAR (°): 0

SPK	SPLAY	TILT	RDNet	Local
SPK 1	0	0	8	M
SPK 2	0.7	-0.7	7	M
SPK 3	1.7	-2.4	6	M
SPK 4	1.7	-4.1	6	M
SPK 5	1.7	-5.8	5	M
SPK 6	1.7	-7.5	5	M
SPK 7	2.7	-10.2	4	C
SPK 8	2.7	-12.9	4	C
SPK 9	3.7	-16.6	4	C
SPK 10	3.7	-20.3	3	C
SPK 11	5	-25.3	3	C
SPK 12	5	-30.3	3	C
SPK 13	0.2	--	--	--
SPK 14	0.2	--	--	--
SPK 15	0.2	--	--	--
SPK 16	0.2	--	--	--
SPK 17	0.2	--	--	--
SPK 18	0.2	--	--	--
SPK 19	0.2	--	--	--
SPK 20	0.2	--	--	--

LF PRESET

RDNet: 3.2
 Local: 3

AUTOSPLAY

Every time the user changes flybar tilt, splay angles, humidity, temperature or height of the array, the software automatically recalculates the presets. It is possible to save and load a project of the Shape Designer using the "Setup" menu.

The autosplay algorithm was developed for optimum coverage of the audience size. The use of this function is recommended for the optimization of the array aiming. A recursive algorithm chooses for every cabinet the best angle available in the mechanics.

It is also possible to export as a text file the presets configuration for air and humidity absorption to RDNet using the "Presets" menu.



Refer to next chapter or to the RD-Net manual for more information about this functionality.

RECOMMENDED WORKFLOW - EASE FOCUS 3

Pending the official and definitive simulation software, RCF recommends the use of RCF Easy Shape Designer together with Ease Focus 3. Because of the need of interaction between different software, the recommended workflow assumes the following steps for every array in the final project:

1. RCF Easy Shape Designer: audience and array setup. Calculation in "autosplay" mode of flybar tilt, cabinet, splays, Low Frequency preset and High Frequency presets.
2. Focus 3: reports here the angles, tilt of flybar and presets generated by Shape Designer.
3. RCF Easy Shape Designer: manual modify of splay angles if the simulation in Focus 3 does not give satisfactory results.
4. Focus 3: reports here the new angles, tilt of flybar and presets generated by Shape Designer.

Repeat the procedure until good results are achieved.

NOTE: the 3D model inside the GLL file permits inside AFMG Focus the selection of the "Local" presets. This implies the use of 4 of the 15 presets for the simulation. This limitation will be overcome with the release of the official RCF simulation software.

LOW AND HIGH FREQUENCY MANAGEMENT

LOW FREQUENCY PRESETS

In the low frequency range the interaction between the sound of single cabinets produces an increase of sound level in low frequencies proportional to the number of loudspeakers that make up the cluster. This effect unbalances the global equalization of the system: the interaction between the loudspeakers decreases, increasing the frequency (they become more directive).

For the control of the displacement described above it is necessary to reduce in the global equalization the level of the low frequencies progressively reducing the gain if the frequency decreases (low shelf filter). The RCF Easy Shape Designer software helps the user to give a recommended cluster preset.

The preset is suggested by the software considering the number of the cabinets in the cluster: the final tuning of the system should be done with measurements and listening sessions, considering the environmental conditions.

LOW FREQUENCY PRESET USING RD-NET

In RDNet software nine presets are available: from Shape Designer it is possible to export the recommended cluster preset and it could be imported directly on RDNet. The export/import procedure is the same for the High or Low Frequencies and it will be explained in the following paragraphs.

The tuning of the system (presets change) should be done in RDNet selecting all the cabinets in the cluster and using proper buttons (up and down arrows) to increase or decrease the number of the preset.

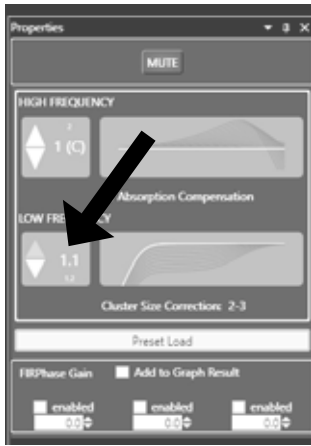

RDNet	Local	Cluster Size
1.1		
1.2	1	4 - 6
2.1		
2.2	2	7 - 9
3.1		
3.3	3	10 - 12
4.1		
4.2	4	13+
4.3		

LOW FREQUENCY PRESET USING REAR PANEL ROTARY KNOB

The available presets in the rear panel of the loudspeaker, named as "Local" in the software, are only four of the nine available in RDNet. The numbers are proportional, in terms of gain, to the reduction applied to the low frequencies of all the clusters.

HIGH FREQUENCY PRESET

The sound propagation, in particular the high frequencies (1.5 KHz and up), depends essentially on the conditions of the air in which it travels. We can generally affirm that air absorbs high frequencies and the amount of absorption depends on temperature, humidity and the distance that the sound should would carry.

The decibel decrease is well modelled by a mathematical formula that combines the three parameters (temperature, humidity and distance) giving a profile of the absorption in function of the frequency.

In the case of a loudspeaker array the goal is the audience coverage with the best possible uniformity, obtainable only by compensating for the absorption introduced by air. It is easy to understand that every cabinet should be compensated differently from the other array cabinets because the compensation should consider the distance at which the cabinet is aiming: the cabinet at the top of the cluster will have a bigger compensation than the one below, which in turn will compensate more than the one below that, etc. The compensation should be translated in terms of decibels that should be progressively added with the increase of high frequencies.

It is important to note that the formula gives an absorption that exponentially increases with the increase of the frequency: in particular conditions the compensation requests a gain too high for the amplifier.

Consider as example the following conditions: 20°C of temperature, 30% of relative humidity and 70m of distance to cover. In these conditions the necessary compensation, from 10 KHz and up, starts from 25 dB up to a maximum of 42 dB at 20 KHz (Figure 5). The headroom of the system cannot permit such high gains.

Considering everything described, 15 compensation levels were selected in order to approximate at best the infinite number of compensation curves derived from the mathematical formula.

A low pass filter is progressively introduced with the increase of the compensation gain: the system does not need to reproduce frequencies that could hardly reach the desired distance and that could lead to a waste of useful energy.

The picture below (Figure 6) shows the behavior of the 15 filters. These filters are designed as very small FIR (finite impulse response) filters in order to preserve the phase coherence of the system.

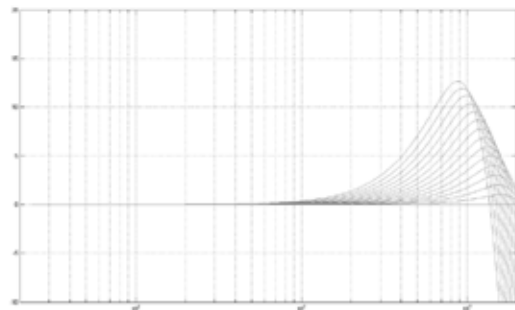
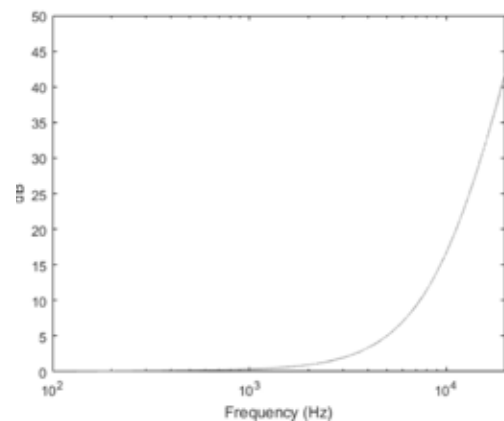

The RCF Easy Shape Designer algorithm calculates the curve that best fits the one that would be seen in the real world. Considering it is an approximation, the generated filters set should be validated with measurements or listening and eventually changed in order to reach the desired listening experience.

HIGH FREQUENCY PRESET USING RDNet

From the RCF Easy Shape Designer it is possible to export the suggested filters set to RDNet; after the selection of all the cabinets in the cluster, by pressing the Load Presets button in the "group" property tab, the user can choose the ".txt" file generated by RCF EASY Shape Designer.

For the proper load of the filters, the group should be composed placing as first loudspeaker of the RDNet cluster the first one below the flybar and then all the others. Every cabinet should load a proper HF preset and the entire cluster should load the same LF preset. Once the presets are loaded, the icon of every module in the cluster shows a green bar with width directly proportional to the number of the preset loaded in the cabinet (the number is shown besides the drawing).

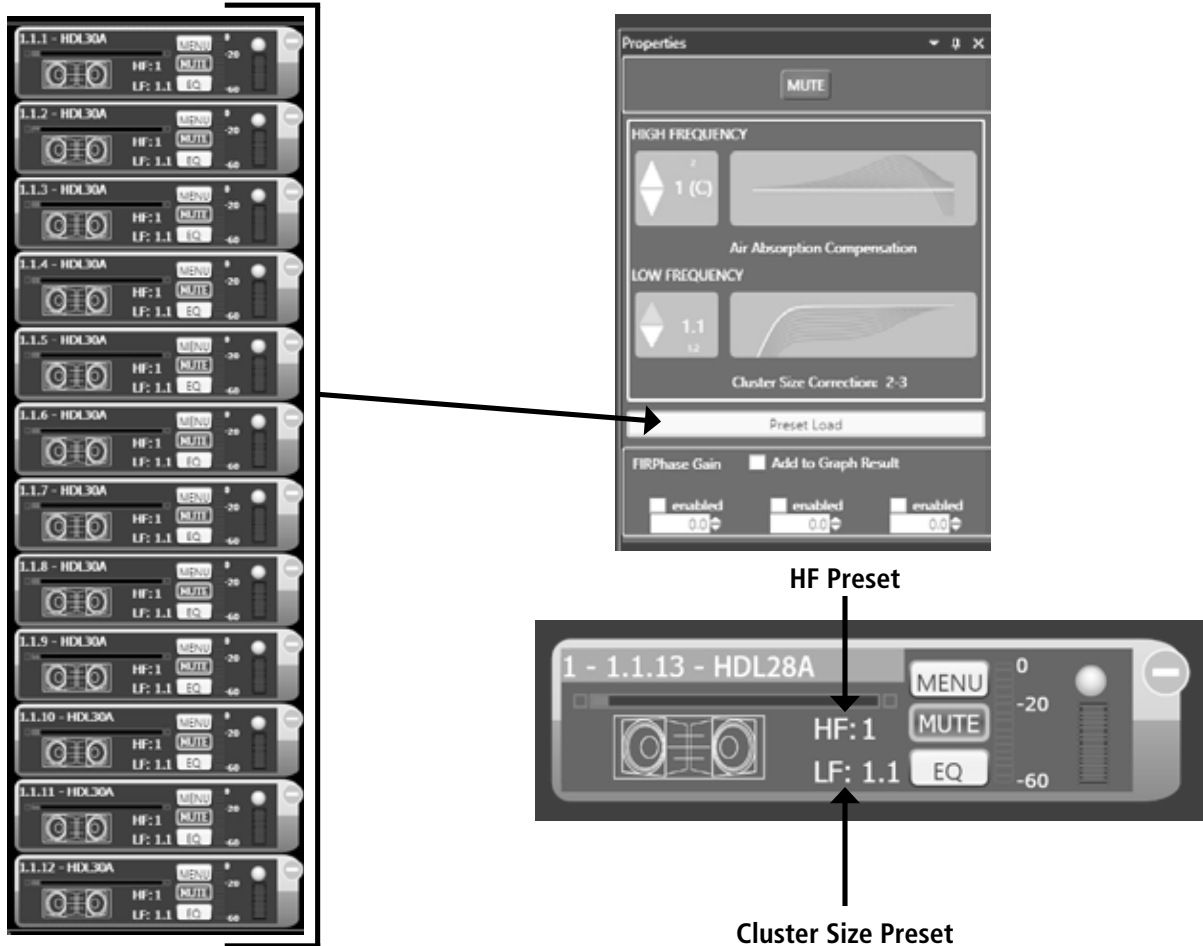

HF Preset

Cluster Size Preset

As described for the Low Frequencies, the user may need to scale up or down the presets set maintaining the compensation ratio between all the cabinets. This scaling operation can be performed with the arrow button in the group tab. Even though the presets change is possible on every single loudspeaker, a global change by using the group properties tab is strongly recommended in order to preserve the air absorption compensation distribution all along the audience.

HIGH FREQUENCY PRESET USING REAR PANEL ROTARY KNOB

From RDNet the user can have access to all the fifteen presets but, using the loudspeaker rear panel rotary knob, he can use only four of those filters. In addition, these "Local" filters are suggested by RCF Easy Shape Designer software.

RDNet	Local
15	-
14	-
13	-
12	H
11	-
10	-
9	F

8	-
7	-
6	-
5	M
4	-
3	-
2	-
1	C

HDL 28-A INPUT PANEL



- 1 FEMALE XLR INPUTS (BAL/UNBAL). The system accepts XLR input connectors.
- 2 MALE XLR SIGNAL OUTPUT. The output XLR connector provides a loop through for speakers daisy chaining. The balanced connector is connected in parallel and can be used to send the audio signal to other amplified speakers, recorders or supplementary amplifiers.
- 3 SYSTEM SET UP ENCODER. Push the encoder to select a function (gain reduction, delay, preset). Rotate the encoder to select a value or a preset.
- 4 POWER LED. This green led is ON when the speaker is connected to the main power supply.
- 5 SIGNAL LED. The signal indicator lights green if there is audio signal present on the main
- 6 PRESET LED. Pushing the encoder three times the preset indicator lights green. Then rotate the encoder to load the right preset to the speaker.
LIMITER LED. The amplifier has a built in limiter circuit to prevent clipping of the amplifiers or overdriving the transducers. When the soft clipping circuit is active the LED blinks RED. It is okay if the limit LED blinks occasionally. If the LED lights continuously, turn down the signal level.
- 7 SYSTEM SET UP DISPLAY. Display the system setting values. In case of RDNNet active connection a rotating segment will light up.
- 8 RDNNet LOCAL SETUP/BYPASS. When released the local setup is loaded and RDNNet can only monitor the speaker. When switched the RDNNet setup is loaded and bypass any speaker local preset.
- 9 RDNNet IN/OUT PLUG SECTION. The RDNNet IN/OUT PLUG SECTION features etherCON connectors for the RCF RDNNet protocol. This allows the user to completely control the speaker using the RDNNet software.

HDL 36-AS INPUT PANEL



- 1 FEMALE XLR INPUTS (BAL/UNBAL). The system accept XLR input connectors.
- 2 MALE XLR SIGNAL OUTPUT. The output XLR connector provides a loop through for speakers daisy chaining. The balanced connector is connected in parallel and can be used to send the audio signal to other amplified speakers, recorders or supplementary amplifiers.
- 3 SYSTEM SET UP ENCODER. Push the encoder to select a function (gain reduction, delay, preset). Rotate the encoder to select a value or a preset.
- 4 GAIN REDUCTION LED. Pushing the encoder once the gain reduction indicator lights green. Then rotate the encoder to reduce the gain to the right level.
POWER LED. This green led is ON when the speaker is connected to the main power supply.
- 5 DELAY LED. Pushing the encoder twice the delay indicator lights green. Then rotate the encoder to delay the speaker. The delay is expressed in meters.
SIGNAL LED. The signal indicator lights green if there is audio signal present on the main
- 6 PRESET LED. Pushing the encoder three times the preset indicator lights green. Then rotate the encoder to load the right preset to the speaker.
LIMITER LED. The amplifier has a built in limiter circuit to prevent clipping of the amplifiers or overdriving the transducers. When the soft clipping circuit is active the LED blinks RED. It is okay if the limit LED blinks occasionally. If the LED lights continuously, turn down the signal level.
- 7 SYSTEM SET UP DISPLAY. Display the system setting values. In case of RDNet active connection a rotating segment will light up.
- 8 RDNET LOCAL SETUP/BYPASS. When released the local setup is loaded and RDNet can only monitor the speaker. When switched the RDNet setup is loaded and bypass any speaker local preset.
- 9 RDNET IN/OUT PLUG SECTION. The RDNET IN/OUT PLUG SECTION features etherCON connectors for the RCF RDNet protocol. This allows the user to completely control the speaker using the RDNet software.

RIGGING COMPONENTS

	Description	Accessory p/n
1	FLYBAR HDL 28-A. Suspension bar to fly a maximum of 20 modules	13360411
2	Front bracket to hook the first module	
3	MOUNTING KIT FL-B PK HDL 30. Hooking bracket and shackle for safety chain	13360394
4	Mount bracket inclinometer	
5	SPARE PINS FRONT 4x HDL20-HDL18. Pin for hooking to the front bracket	13360219
6	SPARE PINS REAR 4x HDL20-HDL18. Pin for hooking to the rear bracket	13360220
7	SPARE PINS 4X FLY BAR HDL20- HDL18. Pin for hooking the braket for stacking applications	13360222
8	Bracket for stacking applications	

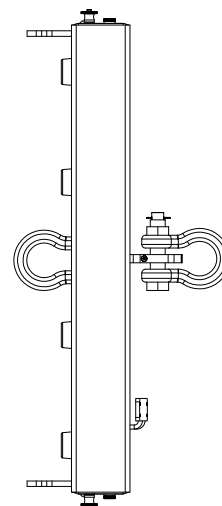
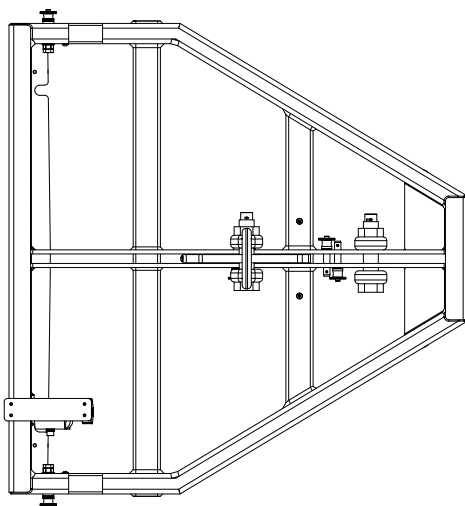
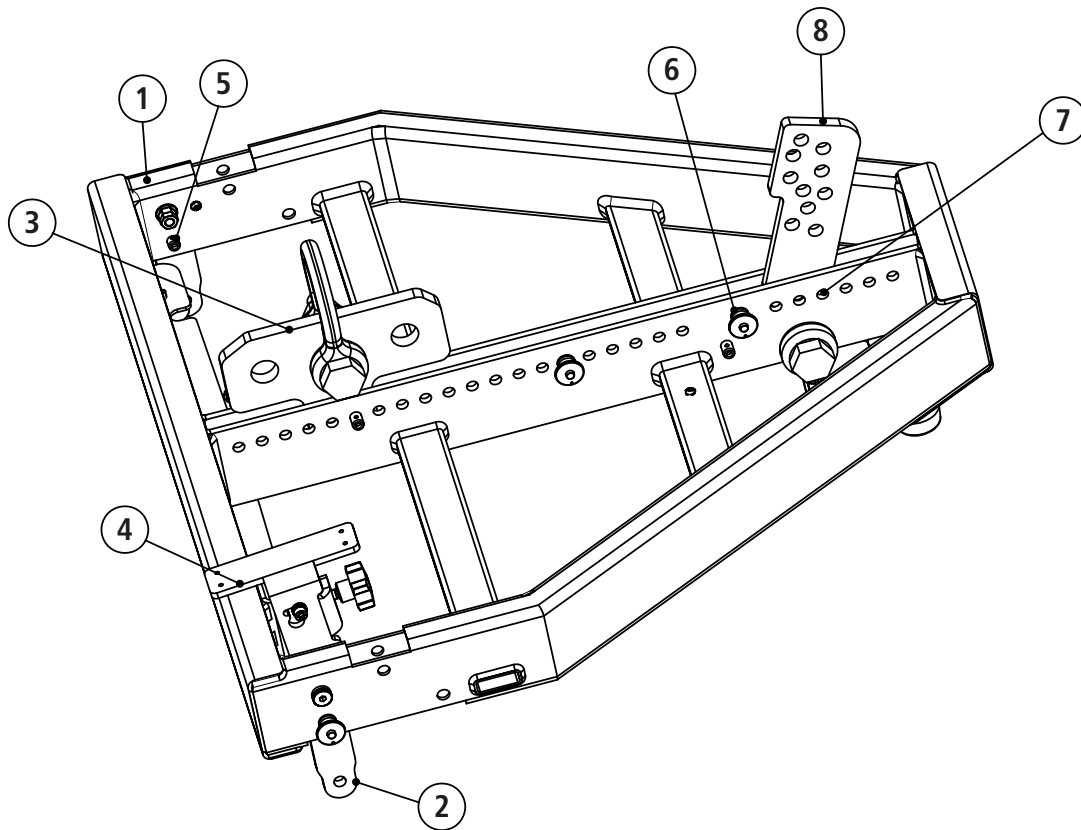

ACCESSORIES

1	13360129	HOIST SPACING CHAIN. It allows enough space for the hang of most 2 motor chain containers and avoids any impact on the vertical balance of the array when it is suspended from a single pick-up point
2	13360351	AC 2X AZIMUT PLATE. It allows the horizontal aim control of the cluster. The system must be hook with 3 motors. 1 frontal and 2 attached to the azimuth plate
3	13360394	MOUNTING KIT FL-B PK HDL 30
4	13360412	KART WITH WHEELS KRT-WH 4X HDL 28. Necessary to carry and rigging 4 HDL 28-A
5	13360393	STACKING KIT STCK-KIT 2X HDL 30. For mounting HDL30-A on Sub 8006, 9004, 9006 and 9007
6	13360431	KART WITH WHEELS KRT-WH 3X HDL 36 Necessary to carry and rigging 3 HDL 36-AS

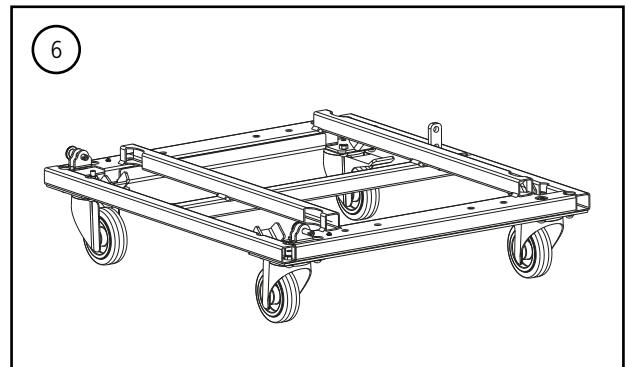
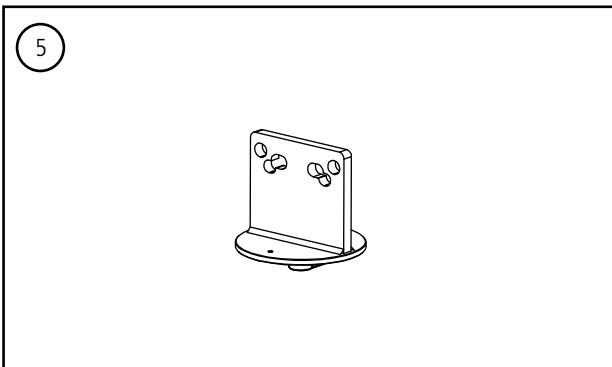
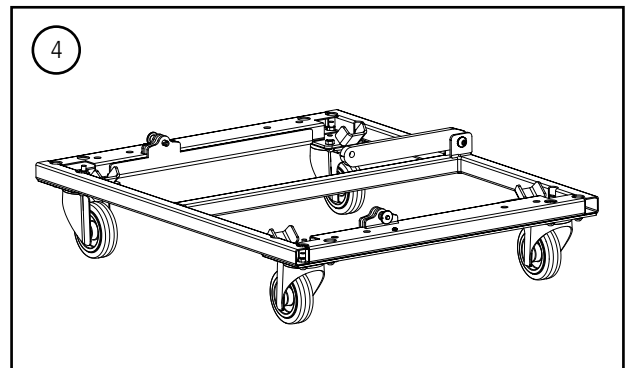
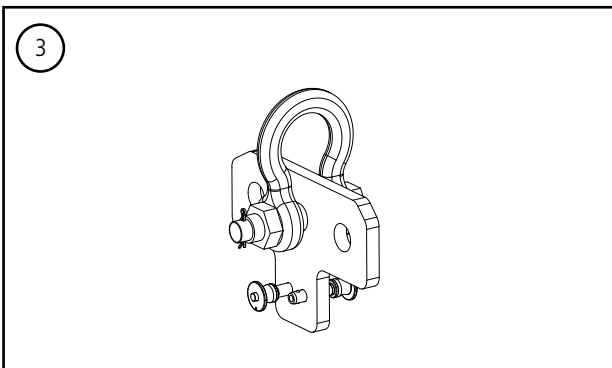
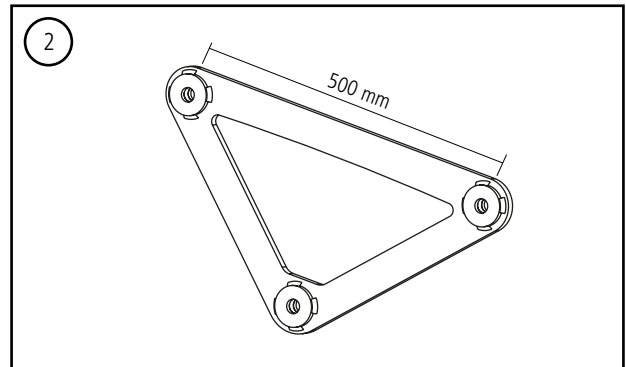
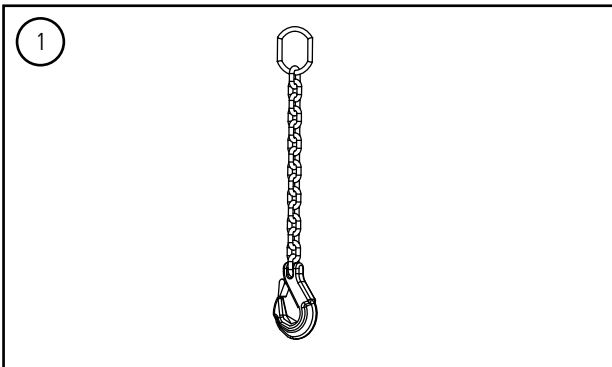

BEFORE INSTALLATION - SAFETY - PARTS INSPECTION

INSPECTION OF MECHANICS, ACCESSORIES AND LINE ARRAY SAFETY DEVICES

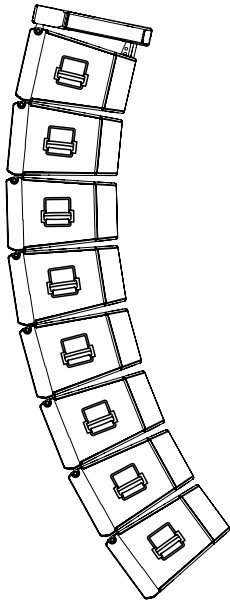

Since this product has been designed to be lifted above objects and people, it is essential to dedicate particular care and attention to the inspection of the product's mechanics, accessories and safety devices in order to guarantee maximum reliability during use.

Before lifting the Line Array, carefully examine all mechanics involved in lifting including hooks, quick lock pins, chains and anchor points. Make sure they are intact, with no missing parts, fully functional, with no signs of damage, excessive wear or corrosion that could compromise safety during use.

Verify that all accessories supplied are compatible with the Line Array and that they are installed correctly according to the instructions provided in the manual. Make sure they perform their function perfectly and are able to support the weight of the device safely.

If you have any doubts about the safety of the lifting mechanisms or accessories, do not lift the Line Array and contact our service department immediately. The use of a damaged device or with unsuitable accessories can cause serious injury to you or other people.

When inspecting the mechanics and accessories, pay maximum attention to every detail, this will help ensure safe and accident-free use.

Before lifting the system, have all parts and components inspected by trained and experienced personnel.

Our company is not responsible for incorrect use of this product caused by failure to comply with inspection and maintenance procedures or any other failure.

BEFORE INSTALLATION - SAFETY - PARTS INSPECTION



INSPECTION OF MECHANICAL ELEMENTS AND ACCESSORIES



- Visually inspect all mechanics to ensure there are no desoldered or bent parts, cracks or corrosion.
- Inspect all the holes on the mechanics; check that they are not deformed and that there are no cracks or corrosion.
- Check all cotter pins and shackles and make sure they perform their function correctly; replace these components if it is not possible to fit them and lock them correctly on the fixing points.
- Inspect any lifting chains and cables; check that there are no deformations, corroded or damaged parts.



INSPECTION OF QUICK LOCK PINS



- Check that the pins are intact and have no deformities
- Test the operation of the pin making sure the button and spring work properly
- Check the presence of both spheres; make sure they are in their correct position and that they retract and exit correctly when the button is pressed and released.

RIGGING PROCEDURE

Installation and setup should only be carried out by qualified and authorized personnel observing the valid national Rules for the Prevention of Accidents (RPA).

It is the responsibility of the person installing the assembly to ensure that the suspension/fixing points are suitable for the intended use.

Always carry out a visual and functional inspection of the items before use. In the event of any doubt as to the proper functioning and safety of the items, these must be withdrawn from use immediately.

WARNING

The steel wires between the locking pins of the cabinets and rigging components are not intended to carry any load. The cabinet's weight must only be carried by the Front and Splay/Rear links in conjunction with the front and rear rigging strands of the loudspeaker cabinets and the Flying frame. Ensure all Locking pins are fully inserted and securely locked before lifting any load.

In the first instance use RCF Easy Shape Designer software to calculate the proper set up of the system and to check the safety factor parameter.

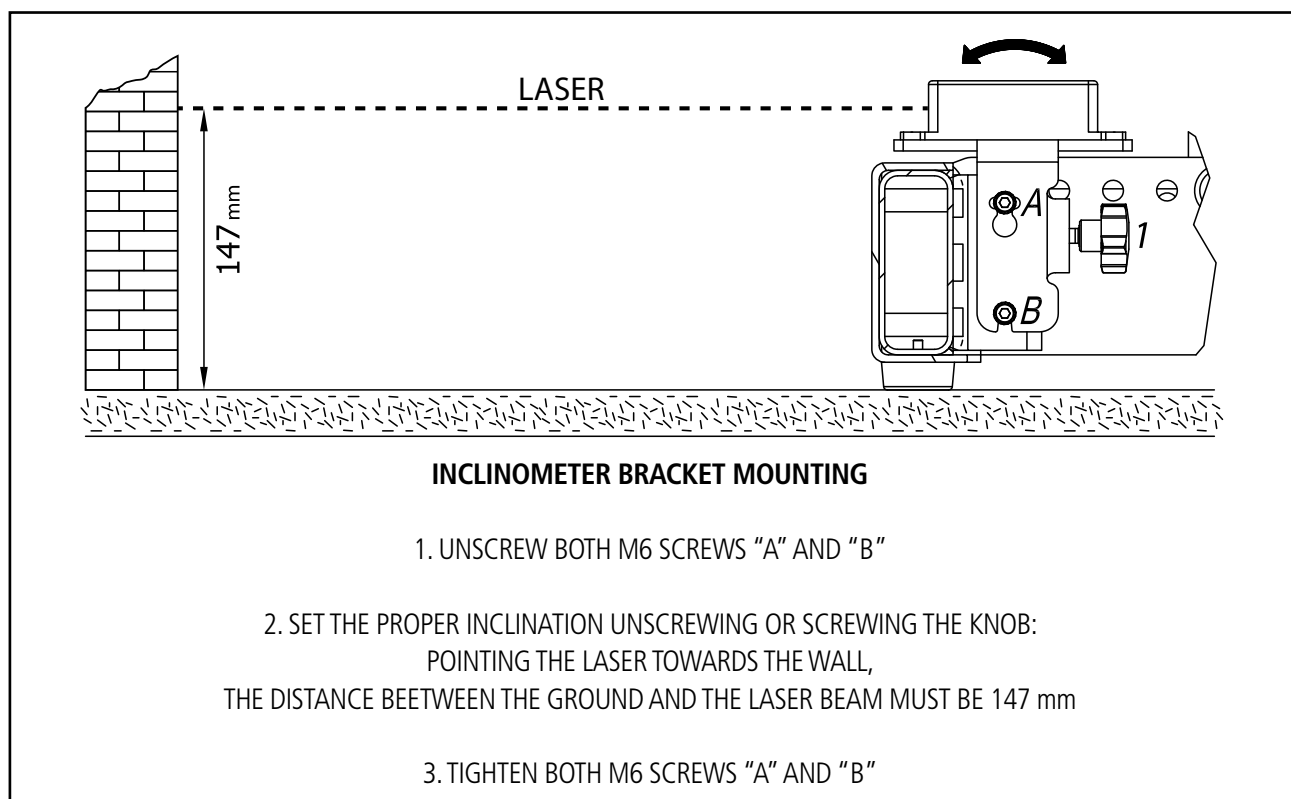

Note that using Rd-Net to set up the system, there will be the possibility to monitor the angles of the flybar and of each single speaker and in case using 1 pick-up point, appropriately calculated by RCF Easy Shape Designer, the cluster will take the proper aim and angles without the need of the inclinometer.

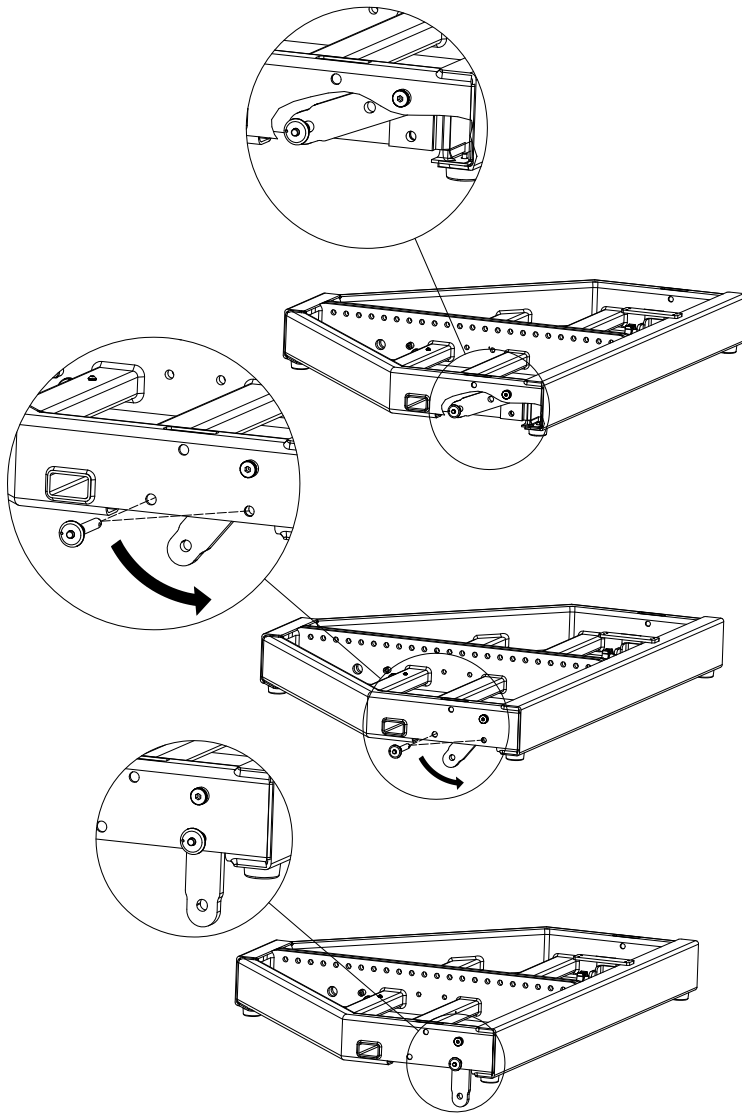

PREPARATION OF THE FLYBAR

Place the flybar and remove the side pins from the transport position. The front bracket will rotate, so lock it. Fix the front brackets in vertical position locking the pins in position 2.

Recheck the Locking pin is securely locked by briefly pulling the Locking pin towards you.

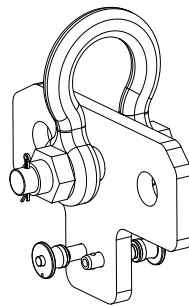
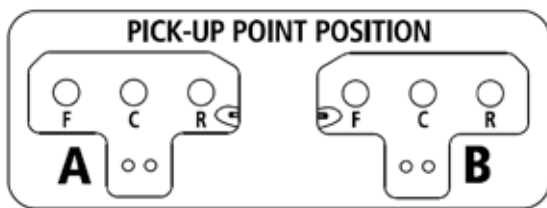

PICK UP POINT POSITIONING

The pickup is asymmetric and can be fit in two positions (A and B). The A position brings the shackle towards the front. The B position allows an intermediate step using the same fixing holes.

Fix the pickup bracket with the two pins on the bracket's lanyard to lock the pickup.

RCF Easy Shape Designer will provide 3 values:

- A **NUMBER** from 1 to 28, which indicates the position of the first pin (considered from the flybar front)
- **A** or **B**, indicating the orientation of the pickup point
- **F, C** or **R** indicating where to screw the shackle. F (Front) C (Center) R (Rear)

For example:

Configuration "14 B C": first pin on hole number 14, pickup point on "B" position, shackle screwed on hole "C".

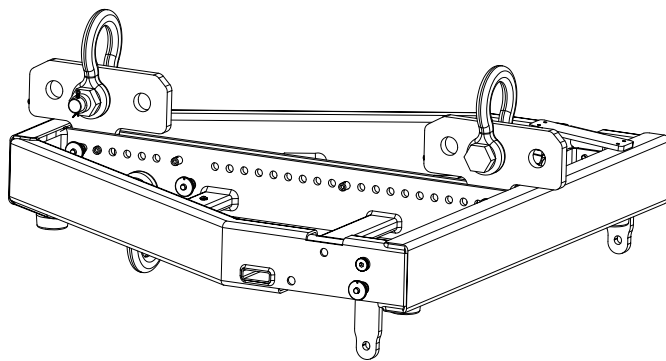
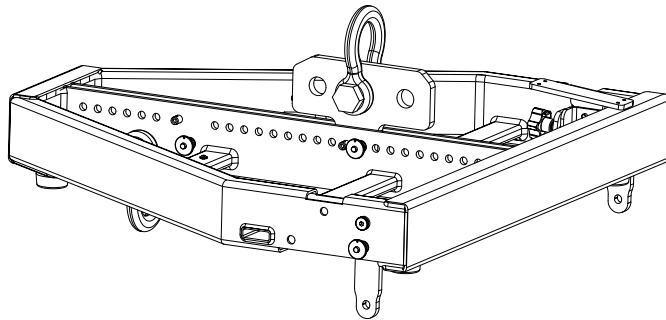
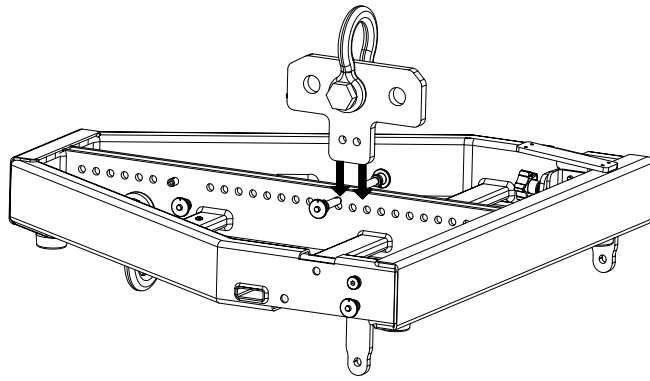

SINGLE PICKPOINT OPERATION
(suggested for 8 modules maximum)

Fit the pickup in the proper position number, (suggested by RCF Easy Shape Designer), and fix the pickup bracket with the two pins. The position of the pickup defines the vertical aiming of the entire array.

Check that all the pins are secured and locked

DUAL PICKPOINT OPERATION

With "Dual pickpoint operation" the vertical aiming of the array is set by trimming the hoist motors after the array has been fully assembled and lifted to its operating position.

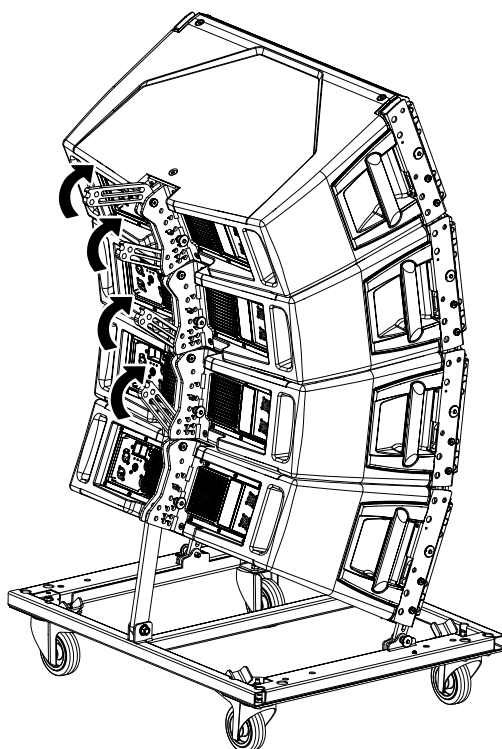
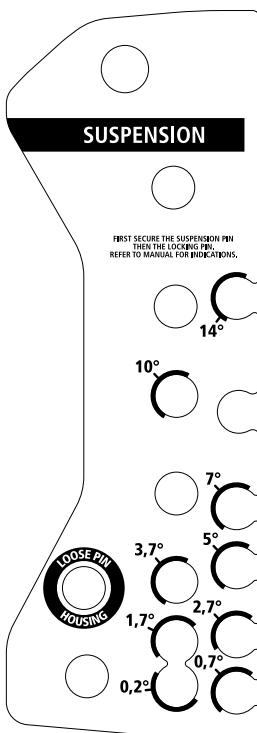

Hook the flybar to the chain and lift the flybar to a suitable height for the first cabinet.

PRESET OF SPLAY ANGLES

1. Remove all the rear locking pins of the cabinets turning the rear bracket into the upper module and inserting the pins in the proper position.
2. Preset the splay angles of all cabinets, based on RCF Easy Shape Designer software

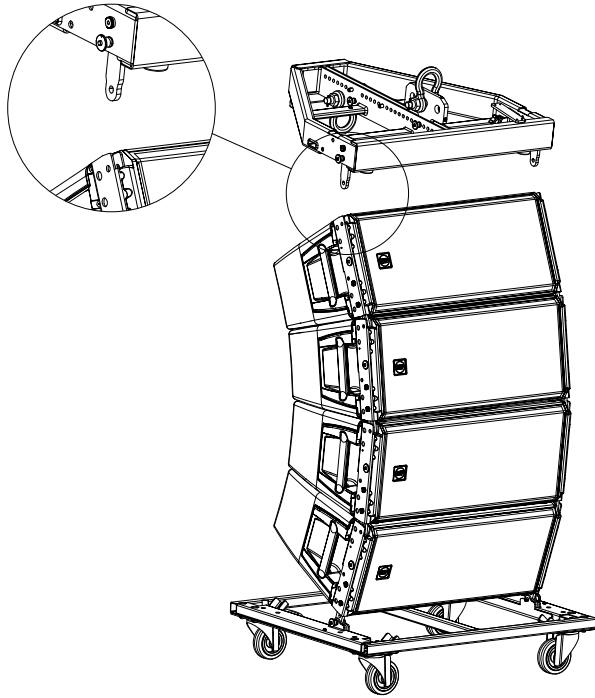

RIGGING THE FLYBAR TO THE SPEAKERS

Move the kart with the first 4 modules under the flybar. Attach the flybar onto the first cabinet of the assembly until the front links fit into the slots at the front of the frame and fix it with the Quick Lock pin supplied with the speaker.

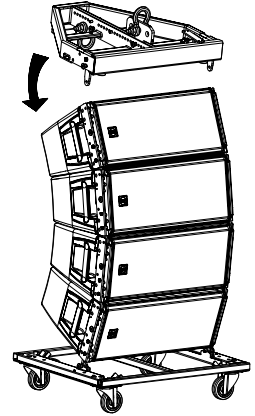

Turn down the flybar until it rests on the first speaker.

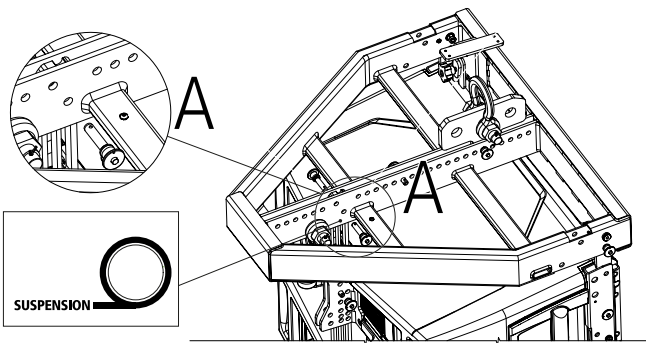

Lift up the rear bracket of the highest cabinet. Insert the quick lock pin in the "suspension" hole "A" of the flybar.

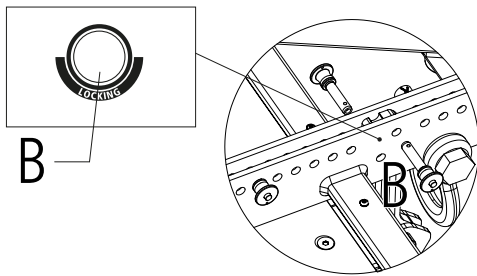

Begin to lift the flybar, and when it goes on traction on the first module, insert the locking pin in the hole "B".

Always follow the sequence "suspension" and "locking" and never use only the locking pin because it is not designed to load the weight of the system. It only prevent the system from going into compression shifting the tilt of the cluster.

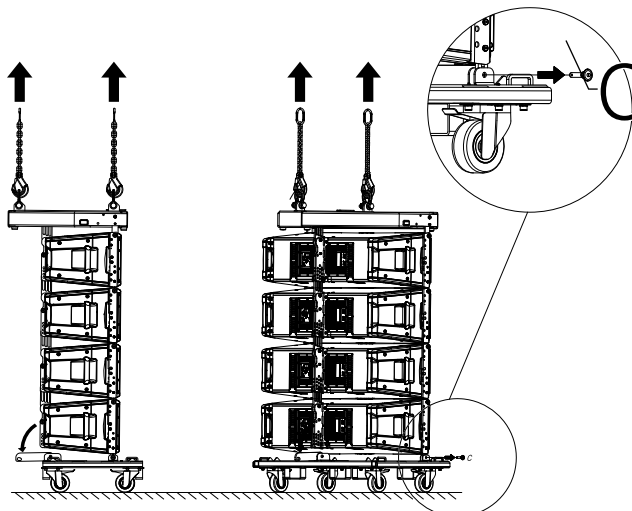

Continue to lift the cluster and the angles of the speakers will automatically switch to the correct position.

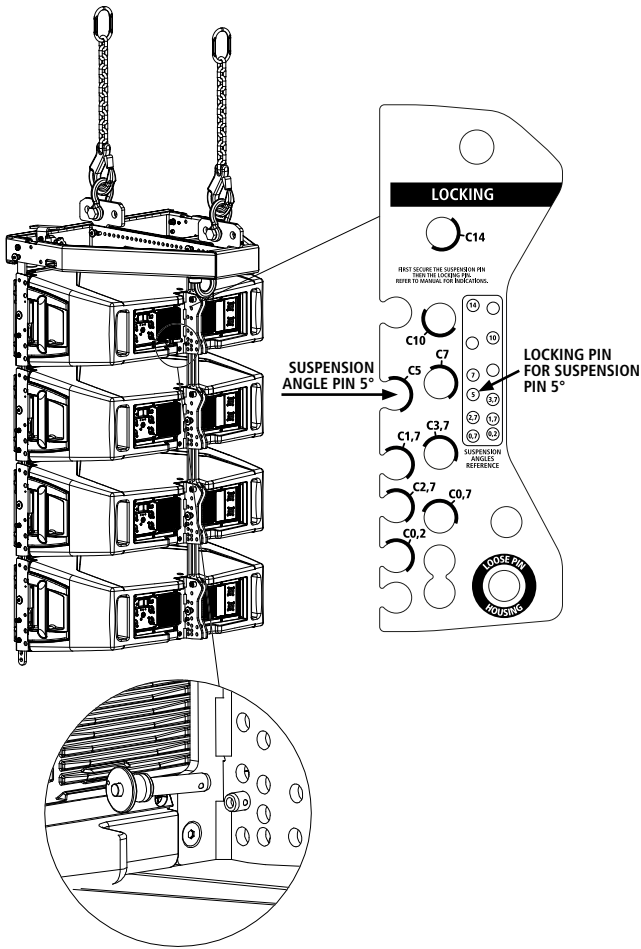

Stop lifting and insert and lock the second Locking pins (Safety pins) to prevent the system from going into compression shifting the tilt of the module, and consequently of the cluster.

Insert the front locking pins in the proper hole. These are 2 additional pins do not load the weight of the system but serve to maintain the fixed angle between the modules especially if they go into compression in very curved systems

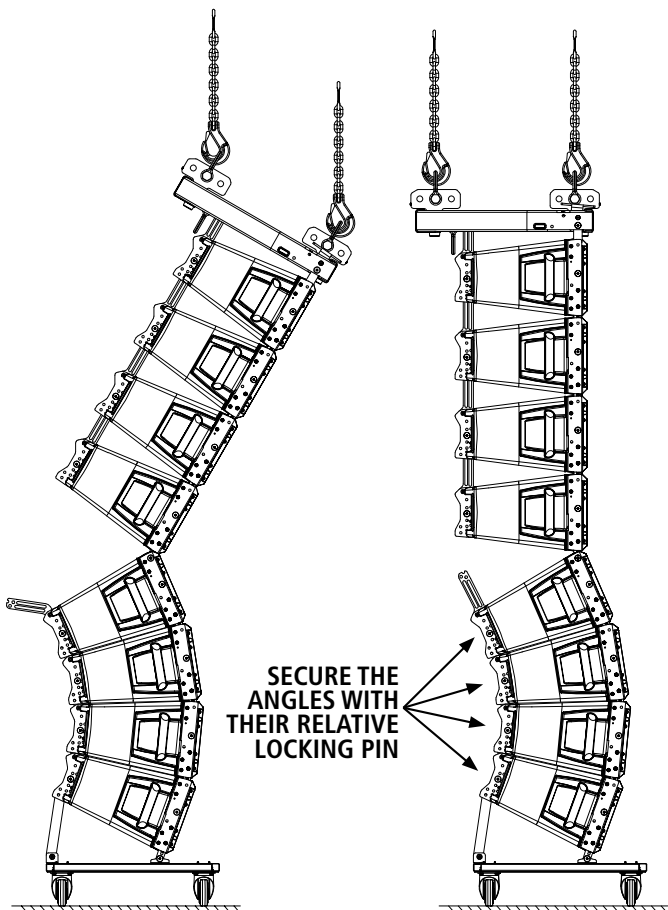

Pull out the front and rear pin from the cart and remove it

Remove all locking pins of the second cart cabinets and preset the splay angles of all cabinets based on RCF Easy Shape Designer software turning the rear bracket into the upper module and inserting the pin in the proper position.

Fix the quicklock pin supplied with the speaker in the proper hole in the front of the last speaker then lower the height of the system in order to reduce the angle between the speakers until they join.

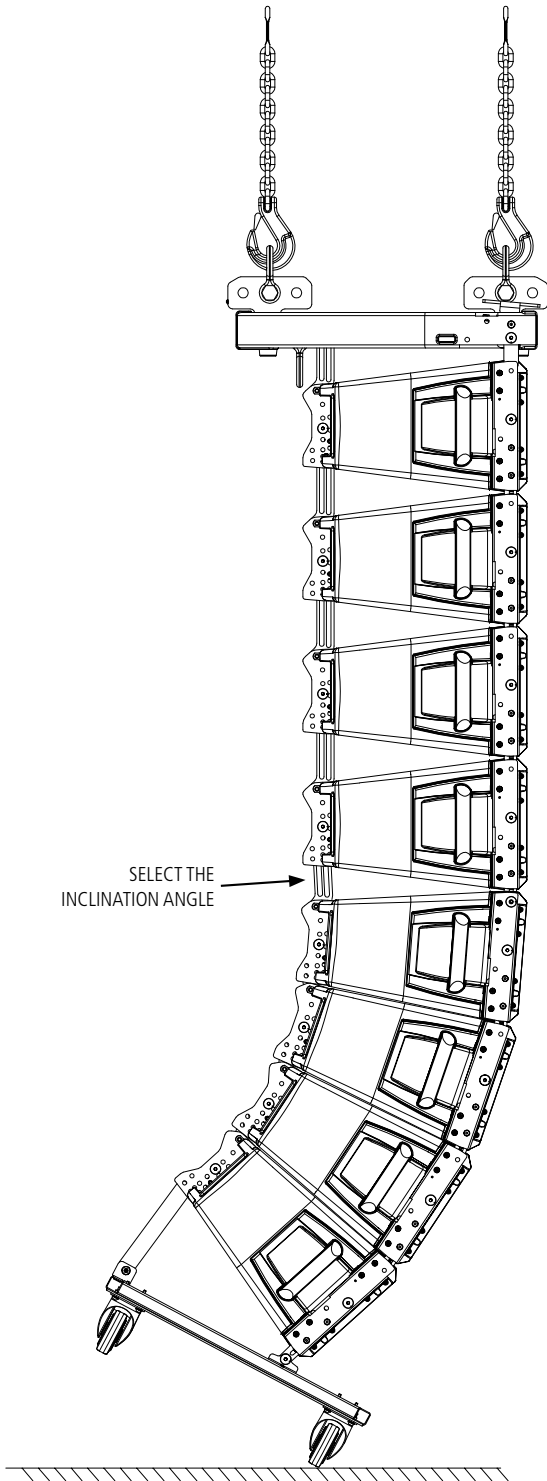

Working with one pick up point this is achieved by pushing forward the cluster and simultaneously lowers the height of the system.

Now fix and lock the quick lock pin between the first speaker of the cluster on the ground and the last of the hanging cluster.

Continue to lift the cluster and the angles of the speakers will automatically switch to the correct position.

Stop lifting and insert and lock the second Locking pins (Safety pins) to prevent the system from going into compression shifting the tilt of the module, and consequently of the cluster.

Insert the front locking pins in the proper hole. These are 2 additional pins do not load the weight of the system but serve to maintain the fixed angle between the modules especially if they go into compression in very curved systems

Pull out the front and rear pin from the cart and remove it. Repeat the procedure of the last 4 module for all of the following modules.

⚠ WARNING

Although with a single pick up point is possible to compose a cluster modules 20, it is highly discouraged to use a single pick up point with more than eight modules. The hooking and lifting of the last modules would be dangerous and difficult.

DE-RIGGING PROCEDURE

Drop the cluster and remove all locking pins while it is still in traction then place the first cart under it.

Lock the front quick lock pins. Turn up the rear bracket of the module while lifting the cart. Go in the proper position with the rear part and insert the quick lock pin in the position corresponding to a 1,4 ° hole.

Drop the cluster until the last module of four is fully leaning on each other.

Remove the rear locking pin of the first module of the next series of four and then remove the quick lock pin. Remove the front quick lock pins, taking great care, because the upper cluster will be free to move.

Pull out the first cluster and repeat the procedure from the beginning.

STACKING PROCEDURE

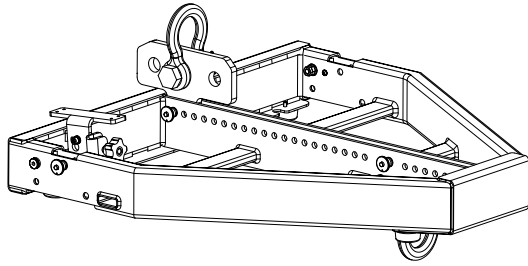

A maximum of 4 x TOP cabinets are allowed to be set up as ground stack.

The assembly of HDL 28-A in stacking uses the same flybar as the hanging process. Proceed as follows:
Remove the pick-up front bracket and remove the laser/inclinometer bracket.

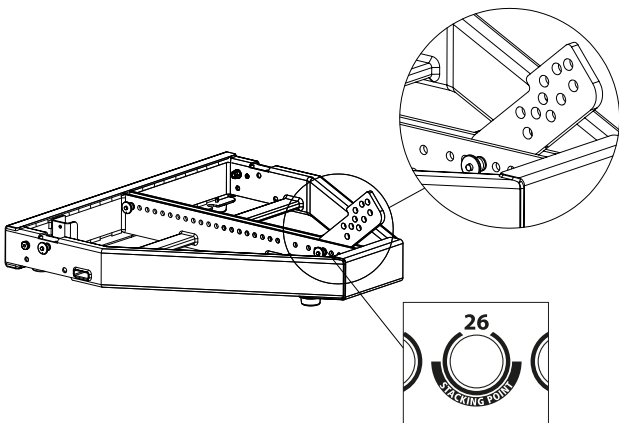

Fix the stacking bracket in the hole number 25 of the flybar and orientate it as shown in fig 2.

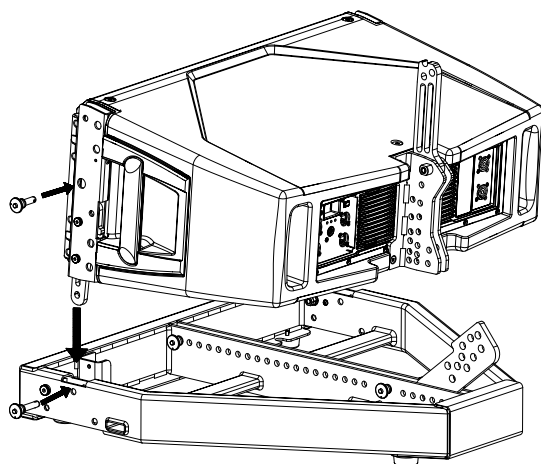

Place the first module fixing the front bracket into the fixing point "A" of the flybar using the quick lock pins of the flybar.

Secure the front brackets by compression.

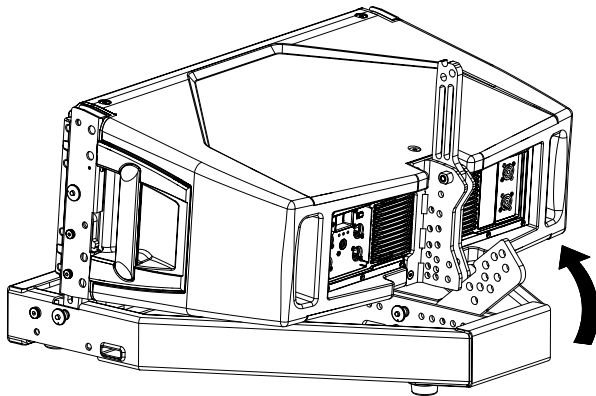

Turn the rear stacking bracket of the flybar and select the proper angle. The correspondence of the bracket's holes is the following:

Stacking Bracket	Rear Rigging Frame
5	1,7
4	Loose Pin Housing WHITE
3	C 0,7
2	C 2,7
1	Loose Pin Housing WHITE
0	C 0,7
-1	Loose Pin Housing YELLOW
-2	Loose Pin Housing WHITE
-3	Loose Pin Housing YELLOW
-4	Loose Pin Housing YELLOW

Insert the locking pin in the proper position

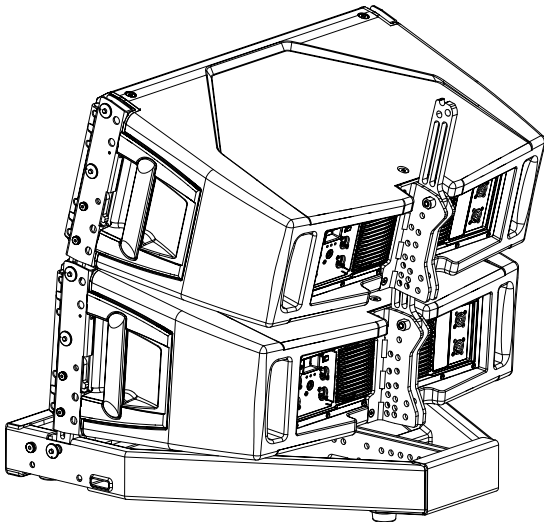

Fix the next module with the front quick lock pins. Lift the rear part of the module, insert the locking pin in the proper position and release the module leaning with the right angle.

Repeat this operation for the following modules.

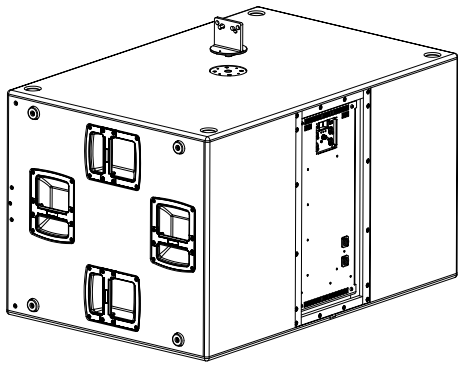

On subwoofers 8006, 9004, 9006 and 9007 series fix the optional accessory "STACKING KIT STCK-KIT 2X HDL 30" cod. 13360393, to M20 female screw on the upper part of the sub.

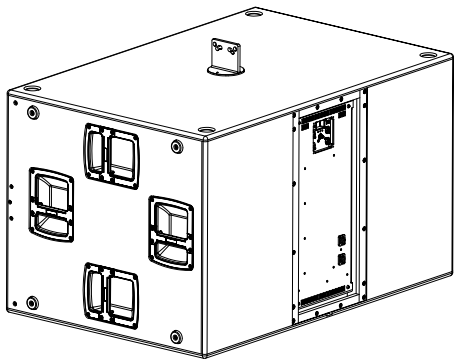
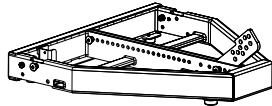

Place the flybar to sub and insert the stacking kit between the two central pipes.

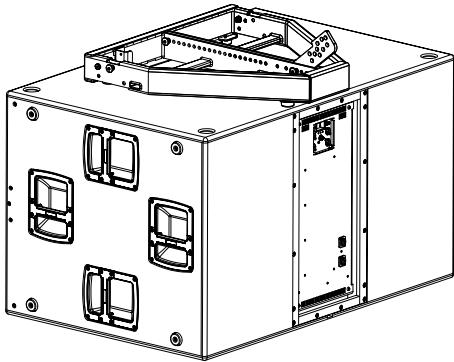

Fix the flybar to the stacking kit using the two quick lock pins.

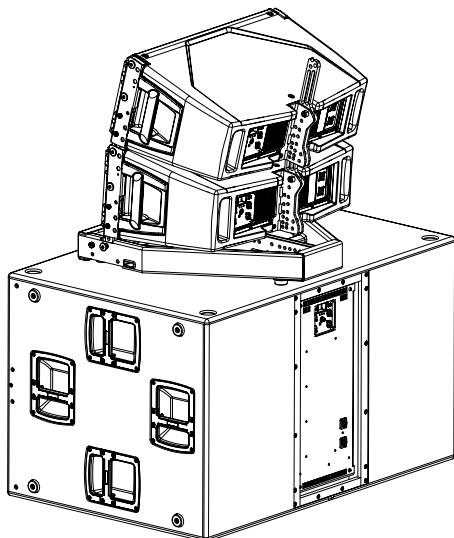

Fix the flybar to the stacking kit using the two quick lock pins.

HDL36-AS STACKING PROCEDURE

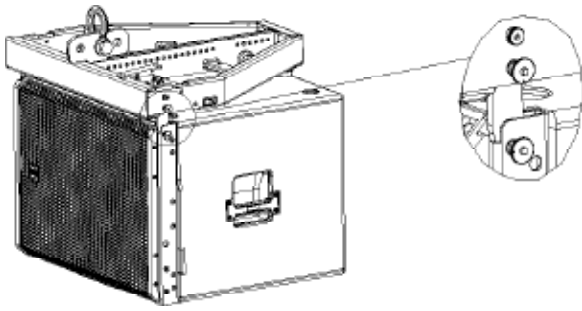

Connect the front bracket to the first HDL36-As cabinet using 2 quick lock pins (1 per side)

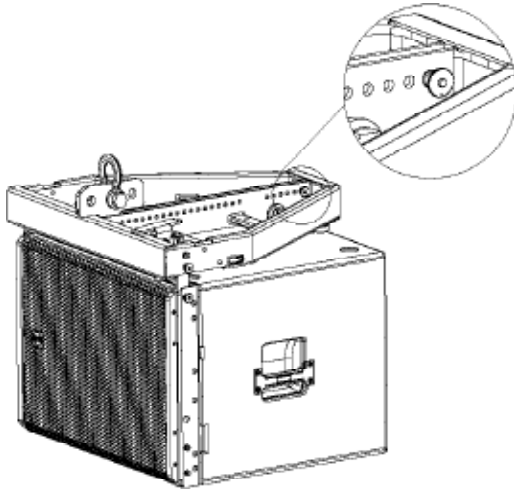

Reverse and connect the rear bracket to the flybar using 1 quick lock pin. The first HDL36-AS has to be fixed forming a 0° angle with the flybar. No other angles are allowed.

HDL36-AS MULTIPLE CONNECTION

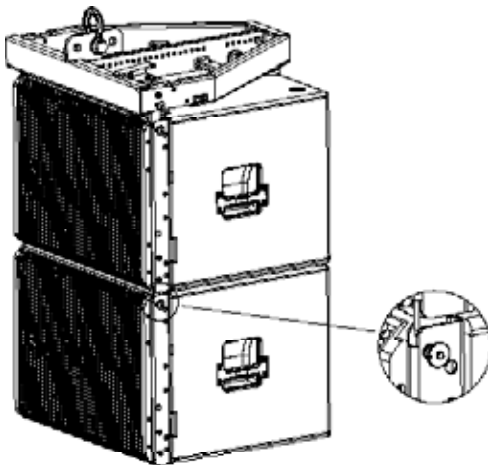

Connect the second cabinet to the first always starting from the 2 front brackets

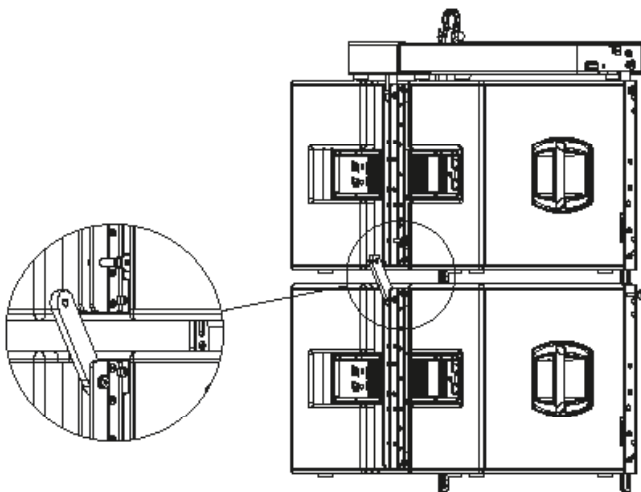

Reverse and connect the rear bracket of the second cabinet using the "rear link" hole.

HDL36-AS & HDL28-A CONNECTION

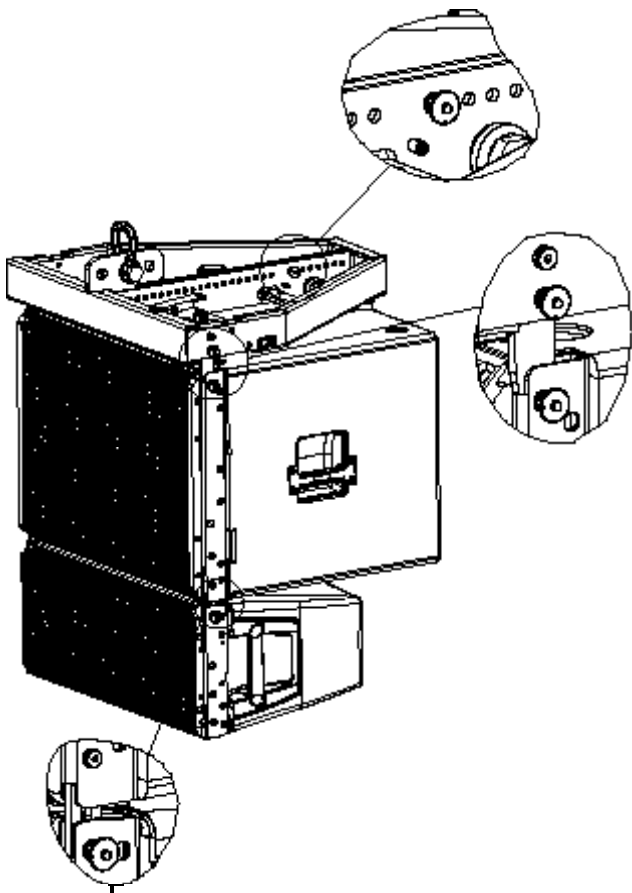

Connect the HDL36-AS front bracket to the HDL28-A front pipe using two quick lock pins

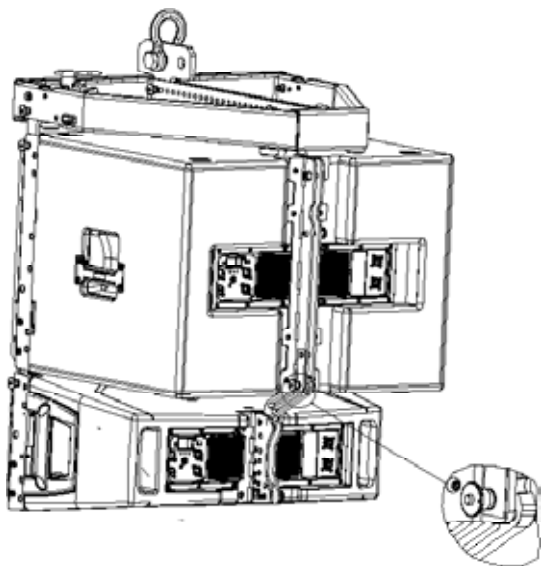

Connect the HDL28-A swinging rear bracket to the HDL36-AS rear frame using 1 quick lock pin. Insert the pin in the external hole (shown below)

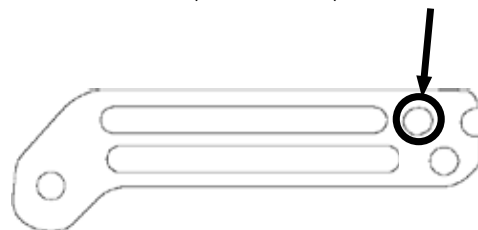

6. CARE AND MAINTENANCE - DISPOSAL

TRANSPORT – STORING

During transportation ensure the rigging components are not stressed or damaged by mechanical forces. Use suitable transport cases. We recommend the use of the RCF HDL28 touring kart for this purpose.

Due to their surface treatment the rigging components are temporarily protected against moisture. However, ensure the components are in a dry state while stored or during transportation and use.

SAFETY GUIDE LINES – HDL28-A KART

Do not stack more than four HDL28-A on one Kart.

Exercise extreme caution when moving stacks of four cabinets with the kart to avoid tipping.

Do not move stacks in the front-to-back direction of the HDL28 (long side); always move stacks sideways to avoid tipping.

**ALWAYS PUSH THE
KART LENGTHWISE**

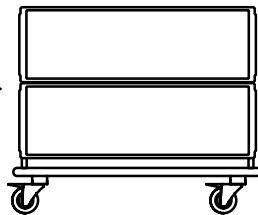

**DO NOT
TILT!**

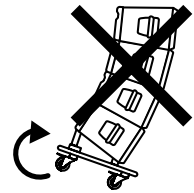

SPECIFICATIONS

	HDL 28-A	HDL 36-AS
Frequency Response	60 Hz - 20 kHz	40 Hz - 140 Hz
Max Spl	135 dB	135 dB
Horizontal Coverage Angle	100°	-
Vertical Coverage Angle	15°	-
Compression Driver	1.4", 3.0" v.c.	-
Woofers	2x8", 2.5" v.c.	15" neo, 4.0" v.c.
INPUTS		
Input Connector	XLR, RDNet Ethercon	XLR, RDNet Ethercon
Output Connector	XLR, RDNet Ethercon	XLR, RDNet Ethercon
Input Sensitivity	+ 4 dBu	+ 4 dBu
PROCESSOR		
Crossover Frequency	800 Hz	Variable from 60Hz to 400Hz
Protections	Thermal, RMS	Thermal, RMS
Limiter	Soft limiter	Soft limiter
Controls	Preset, RDNet Bypass	Volume, EQ, phase, xover
AMPLIFIER		
Total Power	2200 W Peak	3200 W Peak
High Frequencies	600 W Peak	-
Low Frequencies	1600 W Peak	-
Cooling	Forced	Forced
Connections	Powercon in-out	Powercon in-out
PHYSICAL SPECIFICATIONS		
Height	293,6 mm (11.55")	467 mm (18.39")
Width	569,2 mm (22.40")	555 mm (21.85")
Depth	490,6 mm (19.31")	593 mm (23,35")
Weight	18.5 Kg (40.78 lbs)	37 Kg (81.57 lbs)
Cabinet	PP composite	Baltic Birch Plywood
Hardware	Array fittings	Array fittings, pole
Handles	2 side	2 side



www.rcf.it

RCF SpA: Via Raffaello, 13 - 42124 Reggio Emilia - Italy
tel. +39 0522 274411 - fax +39 0522 274484 - e-mail: rcfservice@rcf.it

10307835 RevA